



GemX™ Narrow IntelliFresh® Dispenser and Warmers



GEM3XNRBA026
1.5 Gal. Dispenser, FreshTrac



GEM5XNS10A326
Single Warmer Stand



GEM5XN10A326
Twin Warmer Stand

■ Features

- **Save valuable counter space.** Store two 1.5 Gallon dispensers in the space of a standard GemX.
- **Keep coffee fresher and longer.** Double insulated stainless steel combined with an intelligent warming system. Keeps coffee fresh and hot for one hour.
- **Increase cup quality and consistency.** Restriction brew prevents brewing if old coffee is detected in the dispenser.
- **Mobile technology.** Dispensers are easily movable from the brewer to a remote warming stand. The dispenser remembers when the coffee was brewed and maintains the appropriate LED color to indicate freshness.
- **No site gauge.** Most coffee dispensers use an unreliable plastic site gauge that easily stains, clogs or leaks. GemX Narrow dispensers are all digital, eliminating these hassles while providing a more appealing visual experience.
- **Wrap around faucet guard.** To prevent the faucet from accidental damage, GemX Narrow dispensers feature a faucet guard made with fiberglass-infused plastic.
- **Reduced coffee waste.** Designed with a sloped bottom to ensure all coffee is fully evacuated from the dispenser.

Quality and Volume Level Indicator



Fresh

The green LED will remain lit from 1 - 50 minutes after brewing



Warning

The yellow LED will appear for 10 minutes (50 minutes after brewing)



Expired

The red LED will appear 60 minutes after brewing

Model: GEM3XNRBA026

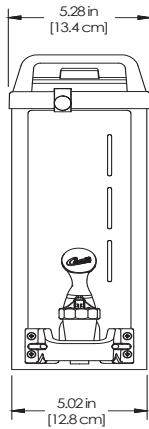

Model: GEM5XNS10A326

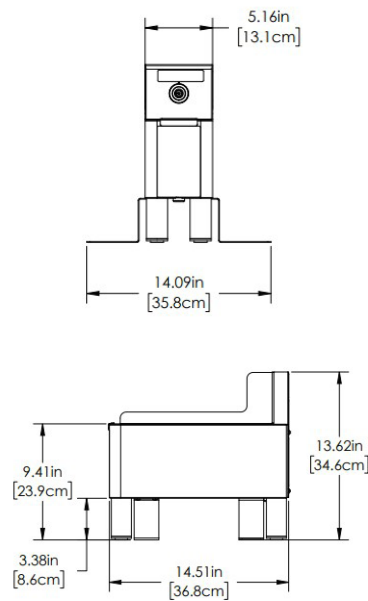

Model: GEM5XN10A326

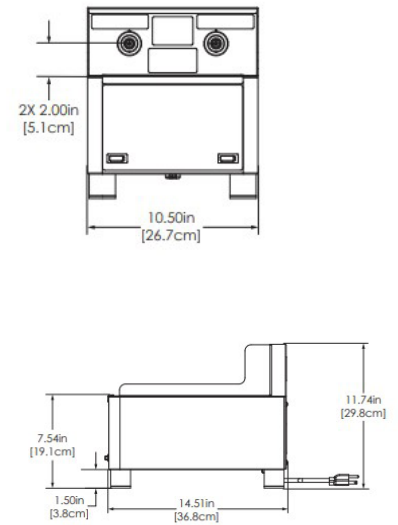

Dimensions

Electrical Requirements

MODEL	DESCRIPTION	H x W x D (Box Dimensions)	SHIP WEIGHT	SHIP CUBE	PHASE	VOLTS	AMPS	WIRE	WATTS	HERTZ	PLUG
GEM5XNS10A326	Single Warmer Stand IF with FreshTrac	20-1/2 x 17-1/2 x 8-1/2	14 lbs	1.8	Single	120	0.60	2W+G	71	50/60	5-15P
GEM3XNRBA026	Dispenser, 1.5 gal. IF FreshTrac, Dispenser Detect	18-5/8 x 14-1/2 x 16	12 lbs	2.5	Single	120	0.60	2W+G	71	50/60	5-15P
GEM5XN10A326	Twin Warmer Stand, IF with FreshTrac	18-5/8 x 14-1/2 x 16	14 lbs	2.5	Single	120	1.20	2W+G	142	50/60	5-15P

Accessories



DT-8
8" Stainless Steel Drip Tray



WC-32005ORG
Decaf Handle

* Accessories sold separately.

