

GEMINI 200R

12 & 24 CUP COFFEE BREWER

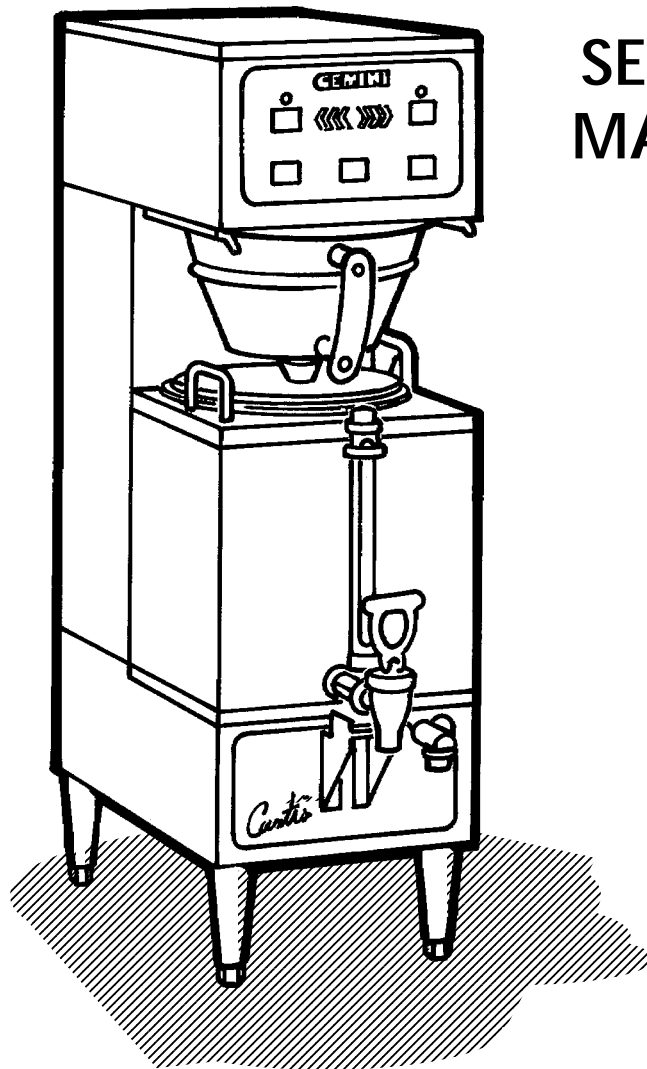

SERVICE MANUAL

Wilbur

Curtis[®]

Co., Inc.

Montebello, California 90640

Tel: 800/421-6150 ❖ Fax: 323/837-2410



Carton Contents

Qty	Item
1	Gemini 200R Coffee Brewer
1	Brewcone
1	Brew Basket
25	Filter Paper
1	Fitting, 3/8 Male NPT x 3/8 Compression Elbow
4	Legs, Adjustable 4" Counter
1	Gem-3, Satellite Server
1	Faucet
1	Guard, Faucet

NOTE:

The installation of this brewer must be performed by professional licensed personnel only. Installation must comply with all city Electrical, mechanical and plumbing codes and regulations. Wilbur Curtis will not accept responsibility if this condition is not met.



WARNING TO HELP AVOID PERSONAL INJURY

Avoid electrical shock, the body of this brewer must be securely grounded. A GREEN grounding screw, located under the drip deck is provided for this purpose.

■ Electrical Data for Gemini 200R Brewer

■ Single Phase, 3 Wire + Ground

Voltage Required: 208-240VAC (120V to Neutral).

Power Consumption: 28 Amps at 220V, 6300 Watts

Circuit Breaker: Recommend 40A Circuit Breaker

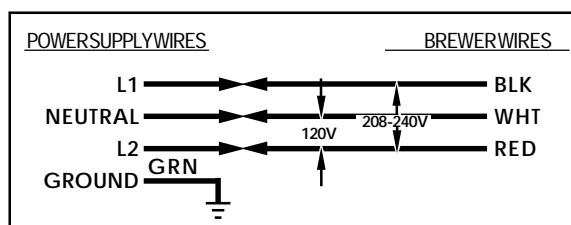

GEMINI 200R COFFEE BREWING SYSTEM

Read and follow Setup Instructions before attempting to use this brewer. This manual should cover most questions you may have about the Gemini 200R. However, if you need additional information, you can call our factory Technical Service Department at (323) 269-8121. When you encounter index numbers in parentheses, following parts mentioned, they refer to the index numbers on the parts list, pages 7 to 10.

SETUP INSTRUCTIONS

1. Carefully unpack shipping carton. Check for any damage.
2. Attach the four adjustable legs, threading them into tapped holes underneath the brewer. Level the machine.
3. Rinse out the brew cone and satellite with water.
4. Hookup electrical and plumbing to comply with all local building codes.
 - A. Remove the panel in back of the machine to gain access to the wiring for electrical hook-up (see fig. 1 to wire power to the brewer).
 - B. Thread the 3/8" compression fitting into the water inlet valve behind the brewer. Run a 3/8" copper tubing water line with a 3/8" flare nut to this fitting. It is recommended that a water shut off valve be installed on the incoming water line to the brewer.

IMPORTANT: Brewer must be connected to COLD water line. Water inlet valves are not rated for hot water.

5. Remove the top cover (1) by loosening four screws.
6. Make sure the thermostat (56) is turned OFF (knob turned all the way counterclockwise), otherwise the heating elements will be damaged if the tank is not filled with water.
7. Open water supply valve.
8. Switch power on at the power switch (45) behind the brewer. This will activate the components in the brewer. Water will now automatically start filling the heating tank and will stop once the water level reaches the probe tip (78).
9. Turn the thermostat ON, by turning knob fully clockwise. Replace top cover.
10. Turn ON the ON/OFF switch (30), located on the front panel.
11. Place Satellite server on warmer deck.
12. Push ON warmer switch (28) to preheat the Satellite server. Before brewing coffee, the Satellite servers must be preheated for ten minutes.

IMPORTANT: Never brew coffee into a cold Satellite. Doing so will result in a lower coffee serving temperature.

13. Allow ten minutes for the water in the tank to reach full temperature. After the initial heat up, temperature recovery is very rapid. You can brew up to two 24-cup cycles before you must allow time for temperature recovery between brews.

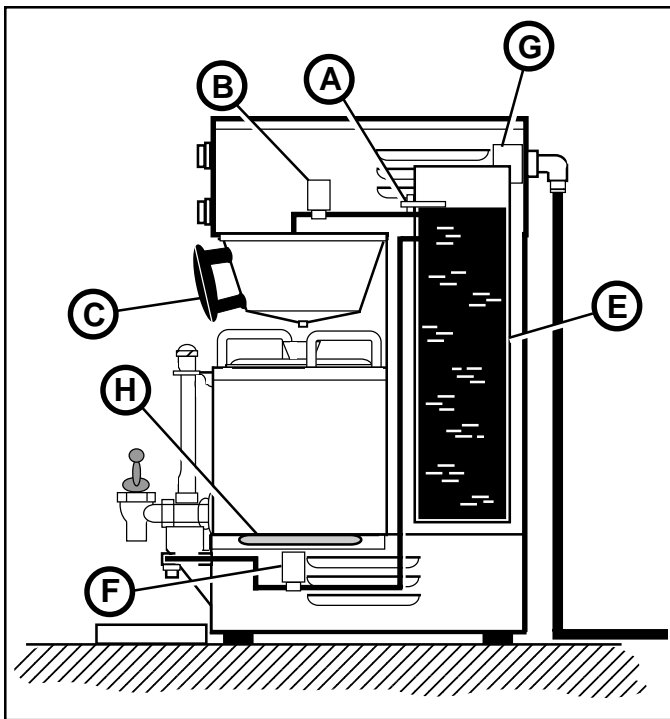

Figure 2. Schematic cross section of Gemini.

FUNCTION OF THE GEMINI

The water in the hot water tank **E**, is maintained at the same level at all times by a sensor called the water level probe **A**. This controls the water inlet valve **G**.

When a brew switch is pushed, the brew cycle is started: The dump valve **B**, is opened by the brew timer, allowing hot water to be sprayed over the ground coffee in the brew basket **C**.

The hot water valve **F**, dispenses hot water for tea, instant beverages, or soups. A warmer element, **H**, keeps the coffee in the Satellite at the proper temperature.

BREWING COFFEE

- Preheat a clean Satellite on the warmer deck for 10 minutes before brewing. Pour ground coffee into the filter and brew cone.
- Slide the brew cone onto the guide rails on the brewer as far in as it will go.
- Press the ½ gallon or the 1 gallon brew switch to start the brew cycle.

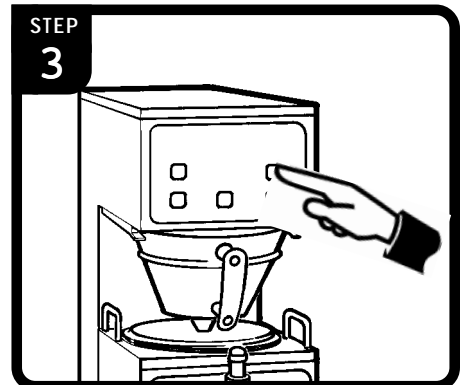
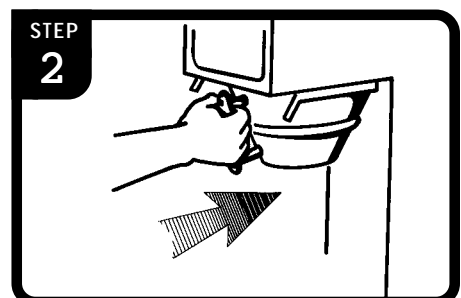
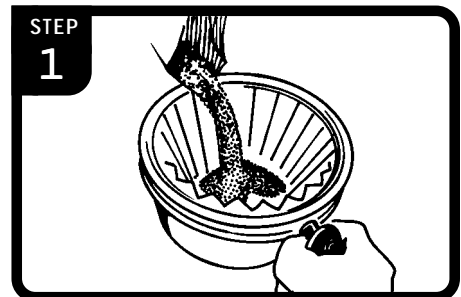

WARNING

TO HELP AVOID PERSONAL INJURY:

- FOLLOW ALL BREWING AND WARMING INSTRUCTIONS.
- HOT NEVER REMOVE BREWCONE UNTIL DRIPPING STOPS.
- USE ONLY CURTIS APPROVED ACCESSORIES.

TIMER ADJUSTMENT

The dual timer (49) is set at the factory to deliver 12 cups (½ gal) or 24 cups (1 gal) of water through the sprayhead (46). To make adjustments on either of the two settings, proceed as follows:

1. Remove top cover by loosening four screws.
2. On the dual brew timer, locate the 12 cup or 24 cup adjustment dial.
3. Twisting the dial shaft clockwise will increase the duration of the brew cycle.
4. Twisting counterclockwise will decrease the brew time.
5. Replace top cover.

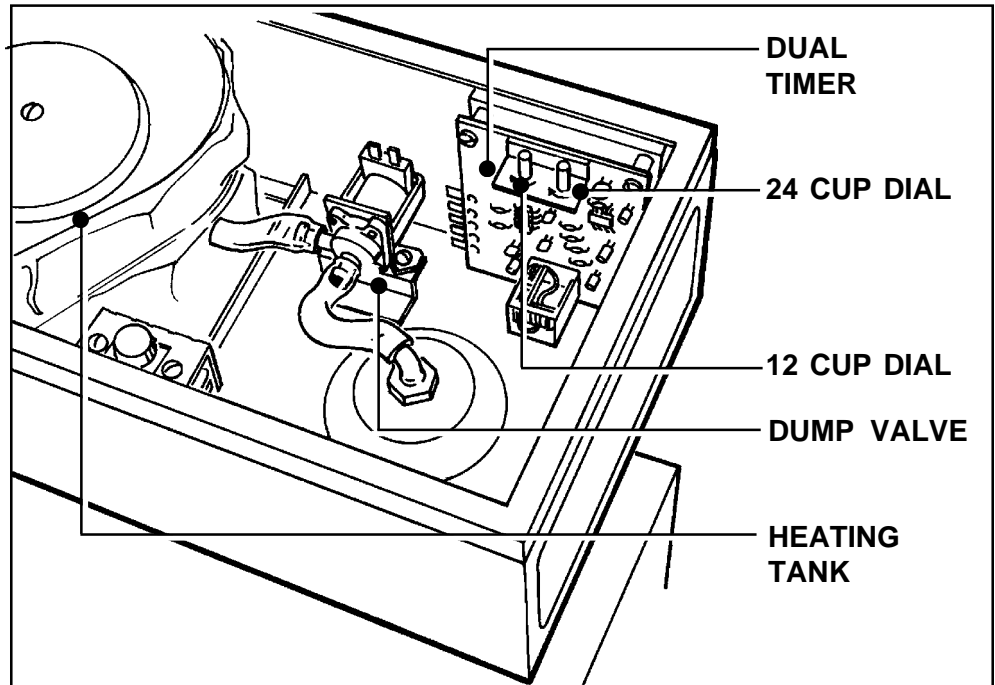

Figure 3. Top view with cover removed, showing timer and other components.

CLEANING & MAINTENANCE

1. Remove sprayhead (46) from the Gemini 200R and clean it once a week or more often in heavy lime areas.
2. Clean faucet seat cups (Illustration, page 12 [23]) once a week, and replace when cracked or leaking.
3. Remove hot water spout aerator (13) and clean it at least once a week.
4. The inside of the heating tank should be de-limed at least every six months or more often in areas with especially hard water.
5. Wipe off any spills, dust or debris from exterior surfaces.
6. Clean the outside of the brewer and satellite with stainless steel polish to prevent scratching of the stainless steel surfaces.
7. Slide out brew cone. Rinse thoroughly with clean water.
8. Clean around sprayhead area, wiping with nontoxic cleaner.
9. Clean brew cone rails with a damp cloth or brush. Dry thoroughly with clean cloth.

CAUTION - When cleaning the Gemini System, do not use cleansers, bleach liquids, powders or any other substance that contains chlorine. These products promote corrosion and will pit the stainless steel. USE OF THESE PRODUCTS WILL VOID WARRANTY.

GEMINI 200R TROUBLE SHOOTING

The Gemini 200R is a simple machine to service. This Trouble Shooting guide will cover most questions you may have about the Gemini 200R. If you find that you cannot remedy a problem on your machine, you may call our factory service department at (323) 269-8121. Index numbers in parentheses refer to index numbers on the Parts List, pages 7 to 10.

IMPORTANT - ANY SERVICE DONE ON THESE UNITS MUST BE PERFORMED BY QUALIFIED SERVICE TECHNICIANS.

WARNING TO HELP AVOID PERSONAL INJURY

Caution must be taken to avoid electrical shock. Be sure power to the brewer is OFF before removing components.

The following steps will also involve working with hot water. Scalding may occur if care is not taken against spilling. Surfaces may be hot.

1. PROBLEM: Heating tank is not filling.

POSSIBLE CAUSE	SOLUTION
Water not flowing into the coffee brewer.	Disconnect the water line from the inlet valve (31) and check to see how much water pressure there is. Reconnect the water line.
Water filter is clogged.	Your filter cartridge may need replacing.
Grounded probe (78).	Whenever the water level in the tank drops below the probe tip, the water inlet valve should open to fill the tank. If the water level is too low, check to see if the probe is grounded. Pull wire terminal off the terminal on the probe. If water flows into the tank, this indicates that the probe has shorted somewhere. Locate the short and correct it. Wrap probe wire with Teflon tape if there is an indication of excessive condensation. Unscrew the probe and polish it with sand paper. Leave 1/8" of tip exposed.
Water inlet valve coil burned out.	Turn off power to the brewer at the toggle switch, (45). Disconnect wires at the inlet valve coil. Connect a lamp cord to the coil terminals and plug into a 120V outlet. Water should flow out of valve. If valve does not respond, clean out or replace valve.
Defective Liquid Level Control board (L.L.C.)(54).	If tests indicate that both the probe and water inlet valve are functioning correctly but low water condition persists; check the operation of the liquid level control board. Measure voltage at the input terminals T2 & T3 of the L.L.C.. Your voltmeter should read approximately 115 volts. It should also read 115 volts at the output terminals T1 & T3 (this output supplies power to the valve coil). Lacking voltage at T1 & T3 terminals will indicate that the L.L.C. is malfunctioning. All wire connections to the board should be tight. Make sure there is contact between the grounding plate on the back side of the L.L.C. and it's mounting bracket. If these tests check out and the board is still inoperative, replace the L.L.C..

GEMINI 200R TROUBLE SHOOTING, CONTINUED

CAUTION Do not turn water supply off and leave brewer on. The coil on the water inlet valve will be damaged.

2. PROBLEM: Water overflowing heating tank.

POSSIBLE CAUSE	SOLUTION
Torn diaphragm or lime build up in water inlet valve seat.	Remove the top cover of the heating tank and check the water level. Switch off the power using the toggle switch, (45), behind the machine. If water continues to flow into the tank, the valve is leaking. Clean, rebuild or replace the valve (valve repair kit #WC-3765).
Lime build up on the water level probe (78). A break in the probe circuit.	Pull off wire with terminal from water level probe. Touch the steel body of heating tank with terminal end of wire. If water flow stops, this is an indication that the probe is probably limed up or has lost it's continuity to the solid state L.L.C. board. Clean probe or look for a break in the circuit and repair it.
Defective L.L.C. Board (54).	Make sure there is contact between the grounding plate on the back side of the L.L.C. board and it's mounting bracket. All wire connections to the board should be tight. Measure voltage at the input terminals T2 & T3 of the L.L.C. board. Your voltmeter should read approximately 115 volts. It should also read 115 volts at the output terminals T1 & T3 (this output supplies power to the valve coil). Lacking voltage at these terminals will indicate that the L.L.C. is malfunctioning. If these tests check out and the board is still inoperative, replace the L.L.C. board.

3. PROBLEM: Water temperature in the heating tank is too low or cold.

POSSIBLE CAUSE	SOLUTION
Thermostat (56) is turned off.	Check to see that the thermostat is turned on. Twist the stem clockwise as far as it will go.
Burned out heating element (68).	Read current with a clamp ammeter on one of the two 10 gauge wires connected to the element. Turn on the machine. The meter should read around 16 amperes. If you cannot get a reading, using a voltmeter, check for voltage across the heating element terminals. If there is approximately 220 volts, the element is burned out.

GEMINI 200R TROUBLE SHOOTING, CONTINUED

4. PROBLEM: Water does not pour from the sprayhead when the brew switch is pushed.

POSSIBLE CAUSE	SOLUTION
Insufficient water in the heating tank.	Check the water level in the tank. If water is not flowing or is flowing too slowly, check the automatic refill system (refer to step 1 of Trouble Shooting).
Defective timer (49).	The power input to the timer is at terminals 1 and 5. Voltage between these terminals should be approximately 115 volts. If you cannot get a reading at these terminals, check the ON/OFF switch (30). When this switch is pressed to the ON position, you should read approximately 115V between terminals 5B and 3A. The same voltage should show at terminals 2 and 5 of the timer. Lack of voltage at these terminals will show that the timer is not opening the dump valve. Replace the timer.
Dump valve coil (37) is burnt out.	If the timer is working, check the coil on the dump valve. If there is voltage, you should read approximately 115 volts between the terminals. If there is voltage, the coil may be burned. Replace coil. Check also for clogging or lime deposits causing the valve to lock up. Clean or replace valve.

TANK LID

This brewer is equipped with a new tank lid design, part no. WC-5661. This new lid does not require the silicone gasket that had been used in previous brewers.

1. When replacing or reinstalling this lid, make sure the tank lip is perfectly round and free from any buildup.
2. The lid must sit in a level position.
3. Make sure that when installing the lid, the bracket or screws do not touch the liquid level probe (see figure 4).

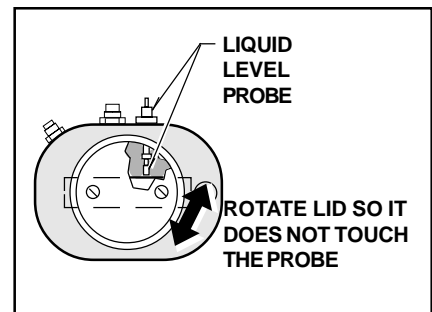
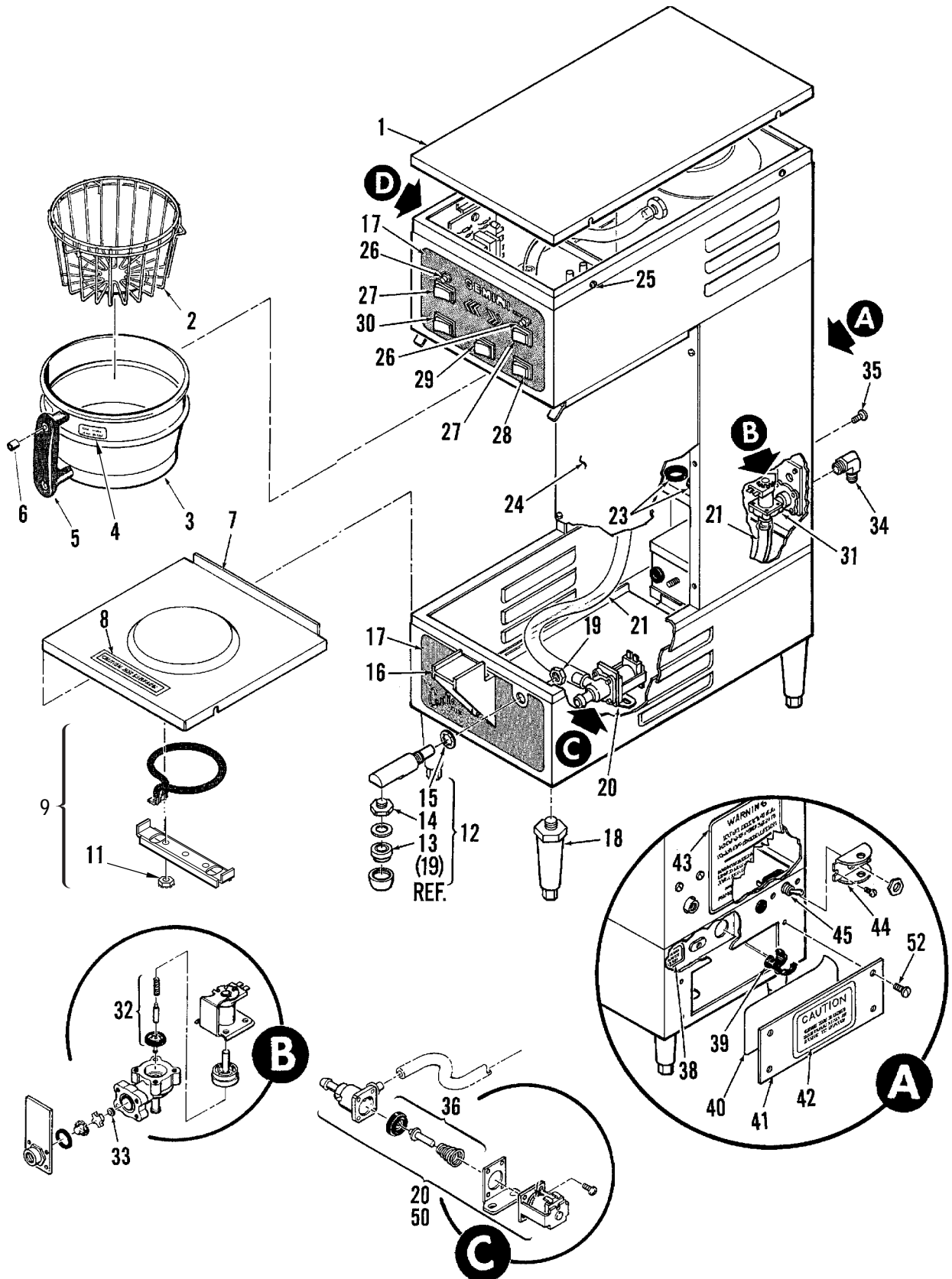

Figure 4. Seating Lid on

Gemini System 200R

Illustrated Parts List.



Gemini System 200R

Illustrated Parts List.

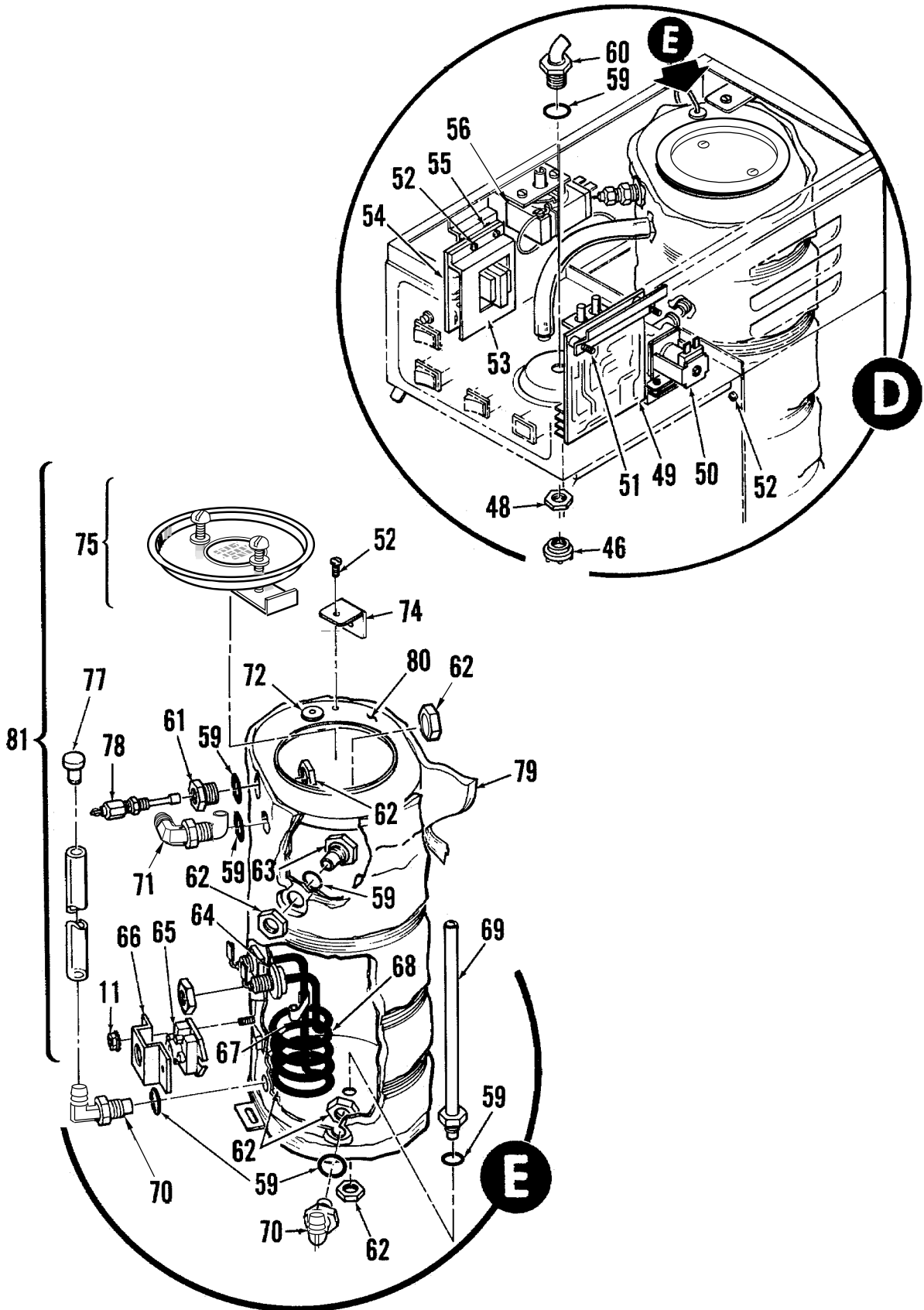

GEMINI 200R

PARTS LIST

INDEX NUMBER	PART NUMBER	DESCRIPTION
1	WC-5450	COVER TOP
2	WC-3314	BREW BASKET, WIRE
3	WC-3313	BREWCONE
4	WC-3963	LABEL, <i>CAUTION REMOVE BASKET SLOWLY</i>
5	WC-3201	HANDLE, BREW CONE
6	WC-4003	RETAINER NUT 10-32
7	WC-5451	WARMER DECK
8	WC-38310	LABEL, <i>CAREFUL HOT SURFACE</i>
9	WC-37102	KIT, WARMER ELEMENT 100W 120V
11	WC-4201	NUT, 8-32 KEP ZINC
12	WC-2912BK	SPOUT, HOT WATER, "NO SPLASH"
13	WC-2946	AERATOR, CHROME PLATED, FEMALE
14	WC-2947	ADAPTOR, AERATOR, CHROME PLATED, MALE
15	WC-4308	WASHER, 1/2" I.D. INTERNAL
16	WC-5424	BRACKET, FAUCET SUPPORT
17	WC-3936-01	LABEL, SWITCH PANEL W/O HOT WATER
18	WC-3500	LEG, 4" ADJUSTABLE COUNTER
19	WC-4205	NUT, 1/4" NPT, BRASS
20	WC- 888WDR	VALVE, HOT WATER 120V 14W W/INTERNAL RESISTOR & DIODE
21	WC-5310	TUBING, SILICONE, 5/16" I.D. x 1 FT.
23	WC-1411	BUSHING, SNAP IN, 5/8"
24	WC-5452	COVER, FRONT
25	WC-4436	SCREW, 4X3/8 PHIL PAN HEAD
26	WC- 200	LIGHT, INDICATOR, 115V
27	WC- 113R	SWITCH, BREW, 125V, GREEN LENS
28	WC- 114R	SWITCH, WARMER, 125V, RED LENS
29	WC- 112R	SWITCH, HOT WATER, 125V, AMBER LENS
30	WC- 111R	SWITCH, ON/OFF, 125V, CLEAR LENS
31	WC- 826L	VALVE, INLET 1GPM 120V 10W
32	WC-3765L	KIT, INLET VALVE REPAIR USE WITH WC-826L
33	WC- 830	WASHER, FLOW, 1GPM
34	WC-2805	ELBOW, 3/8 x 3/8, BRASS COMPRESSOR
35	WC-4616	SCREW, 1/4-20x1/2 PHILLIPS PAN HEAD
36	WC-3763	KIT, REPAIR DUMP VALVE
38	WC-6323	LABEL, GROUND STICKER
39	WC-1408	GRIP, 7/8" CORD
40	WC-3820	LABEL, WARRANTY/WIRING
41	WC-5840	COVER, POWER SUPPLY
42	WC-38149	UNIVERSAL WARNING
43	WC-3848	LABEL, "WARNING- DO NOT INSTALL BREWER W/OUT LEGS"
44	WC-3229	GUARD, TOGGLE SWITCH
45	WC- 103	SWITCH, TOGGLE
46	WC-2936	SPRAYHEAD, RED

GEMINI 200R

PARTS LIST, CONTINUED...

INDEX NUMBER	PART NUMBER	DESCRIPTION
48	WC-4213	NUT, 5/8 BRASS LOCK
49	WC- 616	TIMER DUAL
50	WC- 817	VALVE, DUMP DELTROL, RIGHT
51	WC-4405	SCREW, 6-32 x 7/8" PANHEAD
52	WC-4525	SCREW, 8-32x1/4 PHILLIPS TRUSS HD SS
53	WC-4380	GUARD, SHOCK
54	WC- 608	BOARD, LIQUID LEVEL CONTROL
55	WC-4329	WASHER, #8 EXTERNAL LOCK
56	WC- 517	THERMOSTAT, CAPILARY SPST 277V 22A
59	WC-4320	O' RING
60	WC-2977	FITTING, SPRAYHEAD
61	WC-2938	FITTING, BRASS PROBE HEX
62	WC-4212	NUT, 5/8", BRASS JAM
63	WC-2935	FITTING, TANK OUTLET
64	WC-4306	WASHER, TEFLON, 9/16"
65	WC- 522	THERMOSTAT, HI LIMIT HEATER CONTROL DPST 277V 40A
66	WC-4381	GUARD, RESET THERMOSTAT SHOCK
67	WC-5409	CLIP, THERMOSTAT BULB
68	WC- 922-04	ELEMENT, HEATING 3.5KW 220V W/JAM NUTS & SILICONE WASHERS
69	WC-2957	TUBE ASSEMBLY, HOT WATER
70	WC-29009	FITTING, INLET
71	WC-29010	FITTING, OVERFLOW
72	WC-4314	GROMMET, FDA GRADE SILICONE
74	WC-6301	BRACKET, UPPER TANK SUPPORT
75	WC-37008	KIT, TANK LID ROUND
77	WC-43058	PLUG, TANK DRAIN PP RED
78	WC-5502	PROBE FOR L.L.C.
79	WC-3686	INSULATION, WRAP GEM-200R
80	WC-5492	TANK, HEATING WITH FITTINGS
81	WC-5491	TANK, HEATING COMPLETE

MODEL GEMINI 200R -10	WIRING DIAGRAM VOLTS 220	WIRES 3+ GND WATTS 3675	PHASE Single AMPS 17	HZ 60 DATE 3/24/97	REV.
---------------------------------	------------------------------------	------------------------------------------	---------------------------------------	-------------------------------------	------

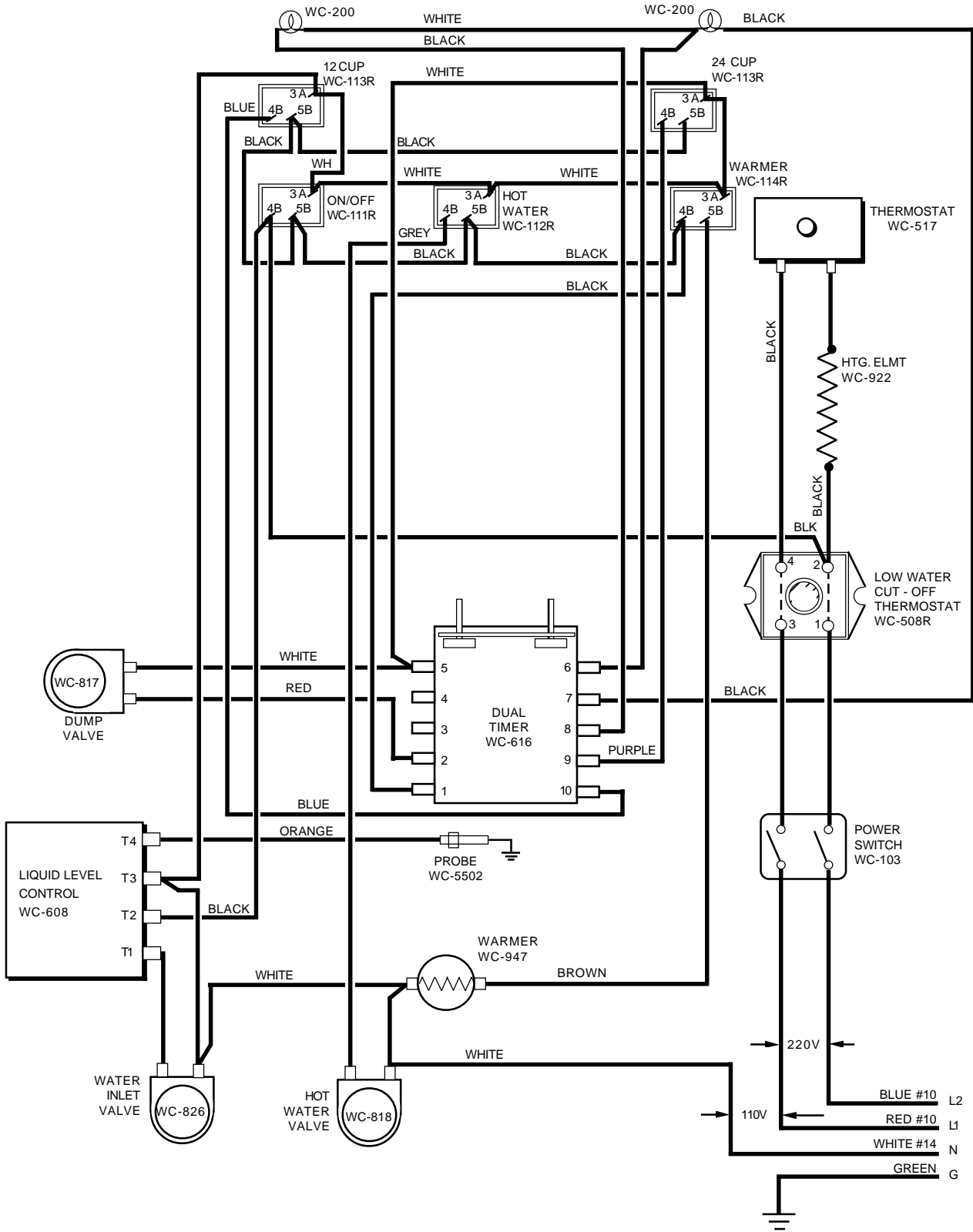

GEM 3, 4 & 5 Parts List

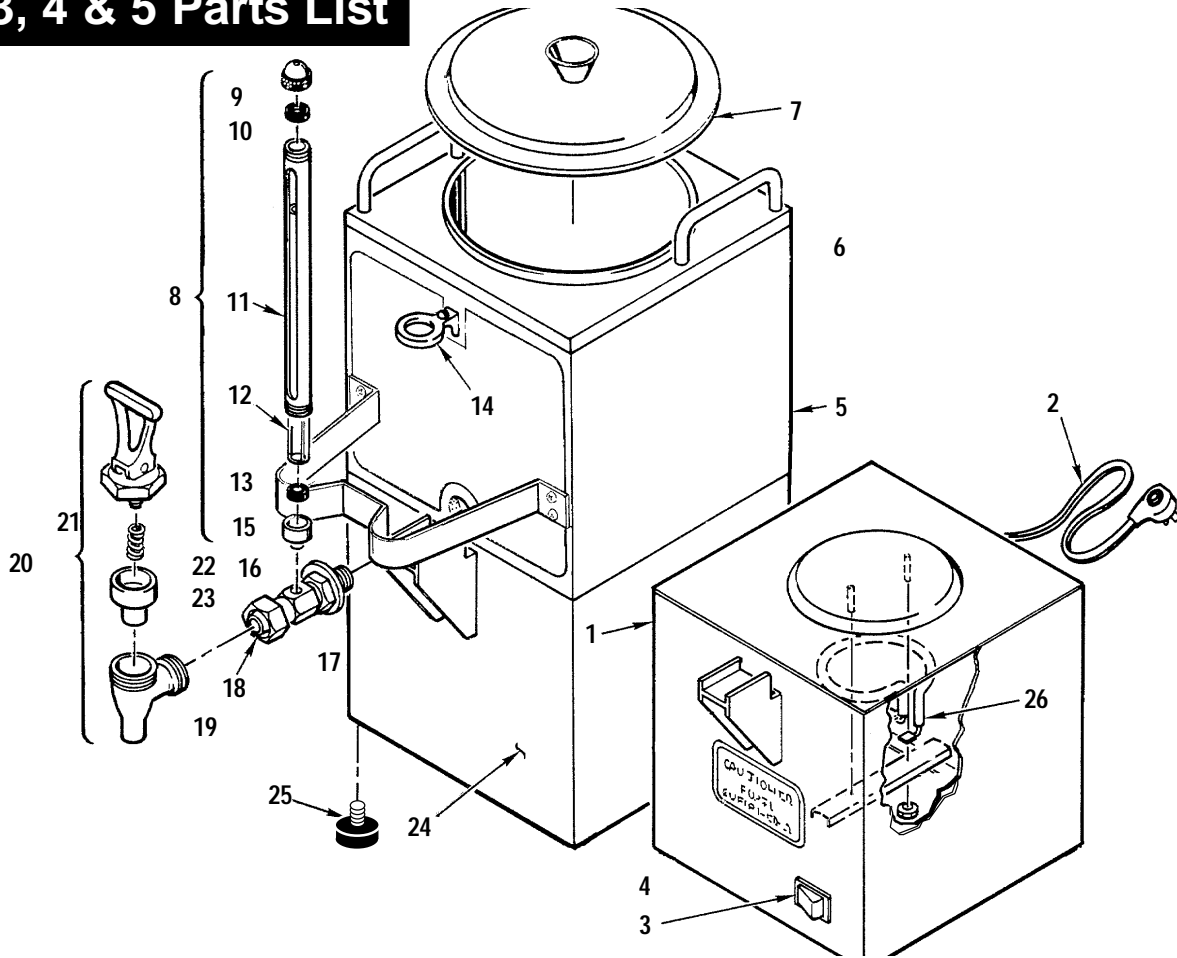

INDEX N°	PART N°	DESCRIPTION
1	GEM-5	SATELLITE WARMER STAND, 115V
2	WC-1386	HARNESS, ASSEMBLY GEM5/8
3	WC-114R	ROCKER SWITCH
4	WC-3811	CAUTION LABEL
5	GEM 3	SATELLITE SERVER COMPLETE
6	WC-5429	SATELLITE BODY ONLY (NO FAUCET OR LID)
7	WC-5622	LID, SATELLITE PLASTIC GEM-3
8	WC-2102	GAUGE GLASS ASSEMBLY, 8 INCH
9	WC-2001	SHIELD CAP WITH VENT 77-4
10	WC-2005	SHIELD CAP WASHER, 1/8"
11	WC-2010C	SHIELD FOR 8 INCH GAUGE GLASS
12	WC-2025	GAUGE GLASS, 8 INCH
13	WC-2006	WASHER FOR SHIELD BASE, 3/16"

INDEX N°	PART N°	DESCRIPTION
14	WC-2007	BRACKET FOR GAUGE GLASS
15	WC-2004	SHIELD BASE
16	WC-1904	SHANK FLANGED NUT
17	WC-1901	FAUCET SHANK D&T
18	WC-1903	SHANK UNION NUT
19	WC-1906	C RING
20	WC-1800	S-FAUCET COMPLETE
21	WC-3705	REPAIR KIT FOR S SERIES FAUCET
22	WC-3402	RETURN SPRING FOR S SERIES FAUCET
23	WC-1805	SEAT CUP S SERIES FAUCET.
24	GEM 4	SATELLITE STAND
25	WC-3503	BUMPER LEG 3/8" THREAD
26	WC-37102	KIT, WARMER ELEMENT 100W 120V

Wiring Diagram Gem -5 & -8 120 Volts, 100 Watts

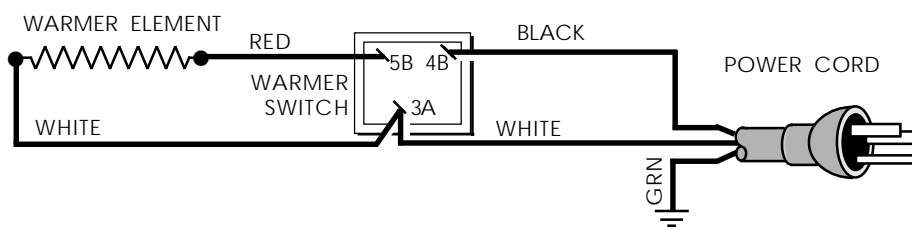

Product Warranty Information

The Wilbur Curtis Company certifies that its products are free from defects in material and workmanship under normal use. The following limited warranties and conditions apply:

- 3 Years, Parts and Labor, from Original Date of Purchase on digital control boards.
- 2 Years, Parts, from Original Date of Purchase on all other electrical components, fittings and tubing.
- 1 Year, Labor, from Original Date of Purchase on all electrical components, fittings and tubing.

Additionally, the Wilbur Curtis Company warrants its Grinding Burrs for Forty (40) months from date of purchase or 40,000 pounds of coffee, whichever comes first. Stainless Steel components are warranted for two (2) years from date of purchase against leaking or pitting and replacement parts are warranted for ninety (90) days from date of purchase or for the remainder of the limited warranty period of the equipment in which the component is installed.

All in-warranty service calls must have prior authorization. For Authorization, call the Technical Support Department at 1-800-995-0417. Effective date of this policy is April 1, 2003.

Additional conditions may apply. Go to www.wilburcurtis.com to view the full product warranty information.

CONDITIONS & EXCEPTIONS

The warranty covers original equipment at time of purchase only. The Wilbur Curtis Company, Inc., assumes no responsibility for substitute replacement parts installed on Curtis equipment that have not been purchased from the Wilbur Curtis Company, Inc. The Wilbur Curtis Company will not accept any responsibility if the following conditions are not met. The warranty does not cover and is void under the following circumstances:

- 1) **Improper operation of equipment:** *The equipment must be used for its designed and intended purpose and function.*
- 2) **Improper installation of equipment:** *This equipment must be installed by a professional technician and must comply with all local electrical, mechanical and plumbing codes.*
- 3) **Improper voltage:** *Equipment must be installed at the voltage stated on the serial plate supplied with this equipment.*
- 4) **Improper water supply:** *This includes, but is not limited to, excessive or low water pressure, and inadequate or fluctuating water flow rate.*
- 5) **Adjustments and cleaning:** *The resetting of safety thermostats and circuit breakers, programming and temperature adjustments are the responsibility of the equipment owner. The owner is responsible for proper cleaning and regular maintenance of this equipment.*
- 6) **Damaged in transit:** *Equipment damaged in transit is the responsibility of the freight company and a claim should be made with the carrier.*
- 7) **Abuse or neglect (including failure to periodically clean or remove lime accumulations):** *Manufacturer is not responsible for variation in equipment operation due to excessive lime or local water conditions. The equipment must be maintained according to the manufacturer's recommendations.*
- 8) **Replacement of items subject to normal use and wear:** *This shall include, but is not limited to, light bulbs, shear disks, "O" rings, gaskets, silicone tube, canister assemblies, whipper chambers and plates, mixing bowls, agitation assemblies and whipper propellers.*
- 9) **Repairs and/or Replacements** *are subject to our decision that the workmanship or parts were faulty and the defects showed up under normal use. All labor shall be performed during regular working hours. Overtime charges are the responsibility of the owner. Charges incurred by delays, waiting time, or operating restrictions that hinder the service technician's ability to perform service is the responsibility of the owner of the equipment. This includes institutional and correctional facilities. The Wilbur Curtis Company will allow up to 100 miles, round trip, per in-warranty service call.*

RETURN MERCHANDISE AUTHORIZATION: *All claims under this warranty must be submitted to the Wilbur Curtis Company Technical Support Department prior to performing any repair work or return of this equipment to the factory. All returned equipment must be repackaged properly in the original carton. No units will be accepted if they are damaged in transit due to improper packaging. **NO UNITS OR PARTS WILL BE ACCEPTED WITHOUT A RETURN MERCHANDISE AUTHORIZATION (RMA). RMA NUMBER MUST BE MARKED ON THE CARTON OR SHIPPING LABEL.** All in-warranty service calls must be performed by an authorized service agent. Call the Wilbur Curtis Technical Support Department to find an agent near you.*



WILBUR CURTIS CO., INC.

WILBUR CURTIS CO., INC.

6913 Acco St., Montebello, CA 90640-5403 USA

Phone: 800/421-6150 ♦ Fax: 323-837-2410

♦ Technical Support Phone: 800/995-0417 (M-F 5:30A - 4:00PPST) ♦ E-Mail: techsupport@wilburcurtis.com

♦ Web Site: www.wilburcurtis.com

Printed in U.S.A. 8/06 F - 1902