

Wilbur Curtis Co., Inc.

ALPHA AUTOMATIC COFFEE BREWERS

SERVICE MANUAL

INCLUDES THE FOLLOWING UNITS:

- ALPHA 3X ● ALPHA 3XR ● ALPHA 3XL
- ALPHA 2X ● ALPHA 1X ● ALPHA 6X

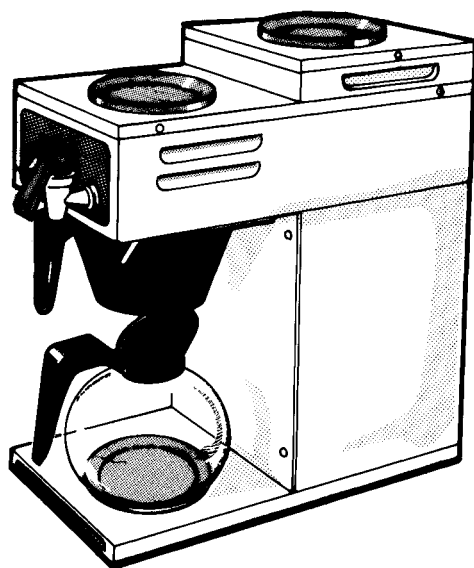

Table of Contents

Setup	1
Coffee Requirements	1
Coffee Brewing	2
Maintenance & Cleaning	3
Trouble Shooting	4 - 5
Illustrated Parts, Alpha 3X	6 - 7
Parts List Alpha 3X	8 - 9
Parts List Alpha 3XR, 3XL, 2X, 6X ..	9
Illustrated Parts, Alpha 3XR & 3XL ...	10
Illustrated Parts, Alpha 2X	11
Illustrated Parts, Alpha 6X	11
Wiring Diagram, Alpha 3X, 3XR, 3XL	12
Wiring Diagram, Alpha 2X	13
Wiring Diagram, Alpha 1X	14
Warranty	Back Cover

Carton Contents

Qty	Item	Part N ^o
1	Automatic Coffee Brewer	Alpha
1	Brewcone	WC-3621
25	Paper Filters	CR-10
1	Elbow Fitting, 3/8 X 1/4 Flare	WC-2401



WILBUR CURTIS CO., INC.

6913 Acco St., Montebello, CA 90640-5403 USA

Phone: 800/421-6150 ♦ Fax: 323-837-2410

♦ Technical Support Phone: 800/995-0417 (M-F 5:30A - 4:00P PST) ♦ E-Mail: techsupport@wilburcurtis.com

♦ Web Site: www.wilburcurtis.com

ALPHA X

The Alpha X series of automatic coffee brewers require installation to be in compliance with all local water and electrical power codes. The Alpha is designed to brew 12 cups at a time. The Alpha 3X, 3XL and 3XR have three warmer plates that allow up to three decanters to be kept at serving temperature. The hot water faucet lets you draw hot water for tea, instant soups, chocolate drinks or cup meals - even during brew cycle.

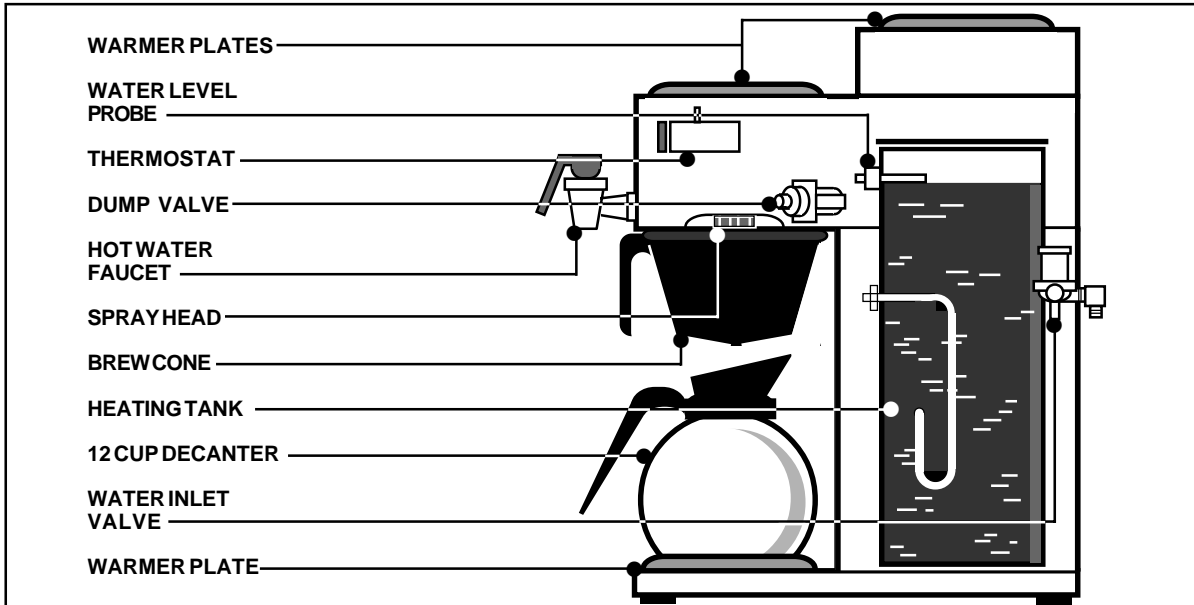

Figure 1. Alpha Brewing System, Basic Components.

SET-UP INSTRUCTIONS

1. **WATER CONNECTION:** A 3/8" NPT x 1/4" flare elbow fitting is supplied with this brewer for the water line connection. Use 1/4" copper tubing and flare nut to hook up your water source behind the machine. It is important to use a good water filter in the system before water enters the Alpha brewer.

CAUTION: Do not connect this brewer to hot water line. Inlet valve is not rated for hot water! Do not connect to water softener system.

2. Remove the top cover and lid from the heating tank. By hand, fill heating tank with water until heating element is submerged.
3. Locate the thermostat (see figure 1). Twist the thermostat stem clockwise as far as it will go.
4. Replace the heating tank lid and top cover.
5. Plug the power cord into a 115 VAC electrical outlet.
6. Turn on power at the *ON/OFF* power switch (front panel). At this time, if the heating tank was not completely filled, the automatic liquid level control will refill the tank.
7. Allow about fifteen minutes for the water in the heating tank to come up to proper temperature. The *READY TO BREW* light will turn on when the initial warm-up has completed. The unit is now ready to brew. Because water expands when heated, there may be a slight overflow discharge at this time.
8. Although this brewer has been thoroughly tested and cleaned at the factory, we suggest that you run several brewcycles of just hot water to flush the water lines of any air that may affect brew volume.

COFFEE REQUIREMENTS

The Alpha coffee brewer will produce excellent results using most grades of coffee available from your coffee distributor. Coffee suppliers can provide coffee in convenient pre-measured envelopes.

The Alpha coffee brewer is designed for *ground* coffee; freeze dried or liquid coffee products will not work.

The Wilbur Curtis Company manufactures bulk coffee dispensers (Models MCD-7 or MCD-7G) that consistently dispense ground coffee in selected amounts.

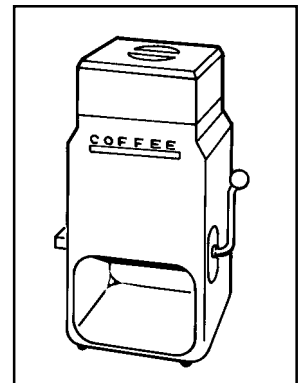
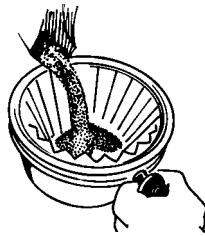

Figure 2. MCD-7G Coffee Dispenser

COFFEE BREWING

1. Place a paper filter into the brew cone.
Pour ground coffee into the filter.



2. Slide the brew cone into place. When pushed in against the stop, the brew cone fits into the slide rails and centers it under the sprayhead.

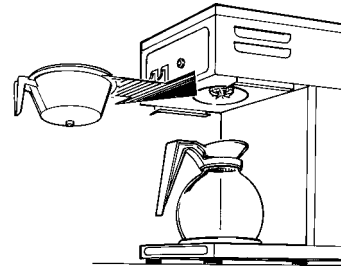

3. Place a clean coffee decanter on the warmer plate.

4. To start brewing, push in the momentary brew switch, located on the front panel. The brew cycle will take approximately three minutes to complete.

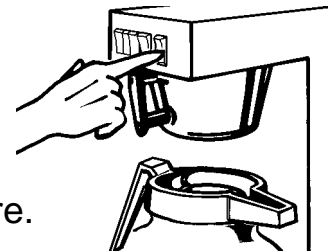

5. The warmer plates keep the coffee at serving temperature. To activate the warmers, push the desired warmer switch, located on the front panel.

WARNING TO HELP AVOID PERSONAL INJURY:

- I FOLLOW ALL BREWING AND WARMING INSTRUCTIONS.
- I HOT COFFEE! ALLOW BREWCONE TO FINISH DRIPPING.
- I USE ONLY CURTIS APPROVED ACCESSORIES.

MAINTENANCE & CLEANING OF BREWER

Regular and preventive maintenance is essential in keeping your Alpha system looking and working like new.

CAUTION When cleaning your Alpha System, do not use cleansers, bleach liquids, powders or any other substance that contains chlorine. These products promote corrosion and will pit the stainless steel. USE OF THESE PRODUCTS WILL VOID WARRANTY.

PREVENTIVE MAINTENANCE

1. Remove the sprayhead from the brewer and clean it once a week or more often in heavy lime areas.
2. Clean the faucet seat cup and replace it if cracked or leaking.
3. The inside of the heating tank should be de-limed at least every six months and more often in areas with especially hard water.

CLEANING

Using a daily routine of cleaning the external parts of the Alpha brewing system should maintain its new appearance and better tasting coffee.

1. Wipe off any spills, dust or debris from the exterior surfaces.
2. Clean the outside of the brewer with stainless steel polish. Coarser agents may scratch the machine.
3. Slide out brew cone. Rinse thoroughly with clean water.
4. Remove the sprayhead and clean. Clean around the dome area, wiping with a non-toxic cleaner.
5. Clean the brew cone rails with a damp cloth or brush.
6. Dry thoroughly with a clean cloth.

TROUBLE SHOOTING

ANY SERVICE DONE ON THIS UNIT MUST BE PERFORMED BY A QUALIFIED SERVICE TECHNICIAN.

PROBLEM: Water does not flow into heating tank...

POSSIBLE CAUSE	SOLUTION
Water line turned off or water filter clogged.	Disconnect the water line and test for water flow.
Coil on Water Inlet Valve has burnt out.	Turn machine off. Disconnect wires from water inlet coil terminals and connect a power cord to the terminals. Plug into a 115V outlet to verify that water flows through when plugged in and stops when cord is disconnected. If the valve does not respond to this test, valve is defective. Replace valve or coil.
Grounded Water Level Probe.	When water in the heating tank is below the probe tip, the tank should be refilling. Pull wire off the probe terminal. If water starts flowing into the tank, probe may be grounded. Clean or replace probe. To reduce the recurrence of grounding, tightly wrap probe with Teflon tape to 1/8" from tip.
Defective Liquid Level Control (LLC) board.	Remove ORANGE wire from probe terminal. Do not allow wire to touch any electrical parts. Test voltage at terminals of Water Inlet Coil. This should read 110 to 220 Volts. If there is no voltage, go to LLC Board. Check board for loose connections or a bad ground. If this is okay, board is defective. Replace LLC Board.

PROBLEM: Water is overflowing from the heating tank

POSSIBLE CAUSE	SOLUTION
Defective Water Inlet Valve.	Turn power off. Observe water level in tank. If water continues to fill tank, the valve may need cleaning or you may have a defective valve. Clean out or replace valve.
Lime deposits on Probe.	Pull wire off from probe terminal. Touch the metal side of water tank with connector end of wire. If water stops flowing, probe needs cleaning or replacement.
Loose or ungrounded Liquid Level Control (LLC) board.	Liquid Level Control board must be securely grounded to it's mounting bracket. Check for loose connections. Make sure there is no voltage present at the inlet valve terminals. If voltage is present, replace LLC board.

PROBLEM: water in tank does not get hot...

POSSIBLE CAUSE	SOLUTION
Thermostat turned off.	Check the thermostat to make sure stem is turned all the way to the right.
Burned out Heating Element.	If thermostat is on (closed) you should read 110/120 volts at the element terminals. Voltage present at these points but no heat, indicates the element is burned out. Replace it.

PROBLEM: Water does not spray over coffee...

POSSIBLE CAUSE	SOLUTION
Clogged Spray Head	Remove the spray head from the brewer and inspect for obstructions. Clean and reinstall.
No water in Heating Tank.	Remove tank lid. Determine if there is water in the tank. Follow instructions on page 3, <i>Problem: Water does not flow into Heating Tank</i> .
Defective Brew Switch.	Check the brew switch for continuity between terminals 1 (white wire) and 2 (blue wire). While pressing the switch. If there is no continuity or if you have to push the switch three or four times to read any continuity. Replace the brew switch.
Defective Timer.	When the timer is activated by the Brew Switch you should read 110 to 120 volts across terminals 6 and A of the timer. The RED wire on terminal 6 supplies power to open the Dump Valve. If you can't read any voltage across the two terminals, replace the timer.
Burned out Dump Valve.	Check the dump valve coil using a volt meter on the dump valve terminals. If it is showing 110 to 120 volts but valve does not actuate, valve is defective; replace the valve.

ALPHA

ILLUSTRATED PARTS

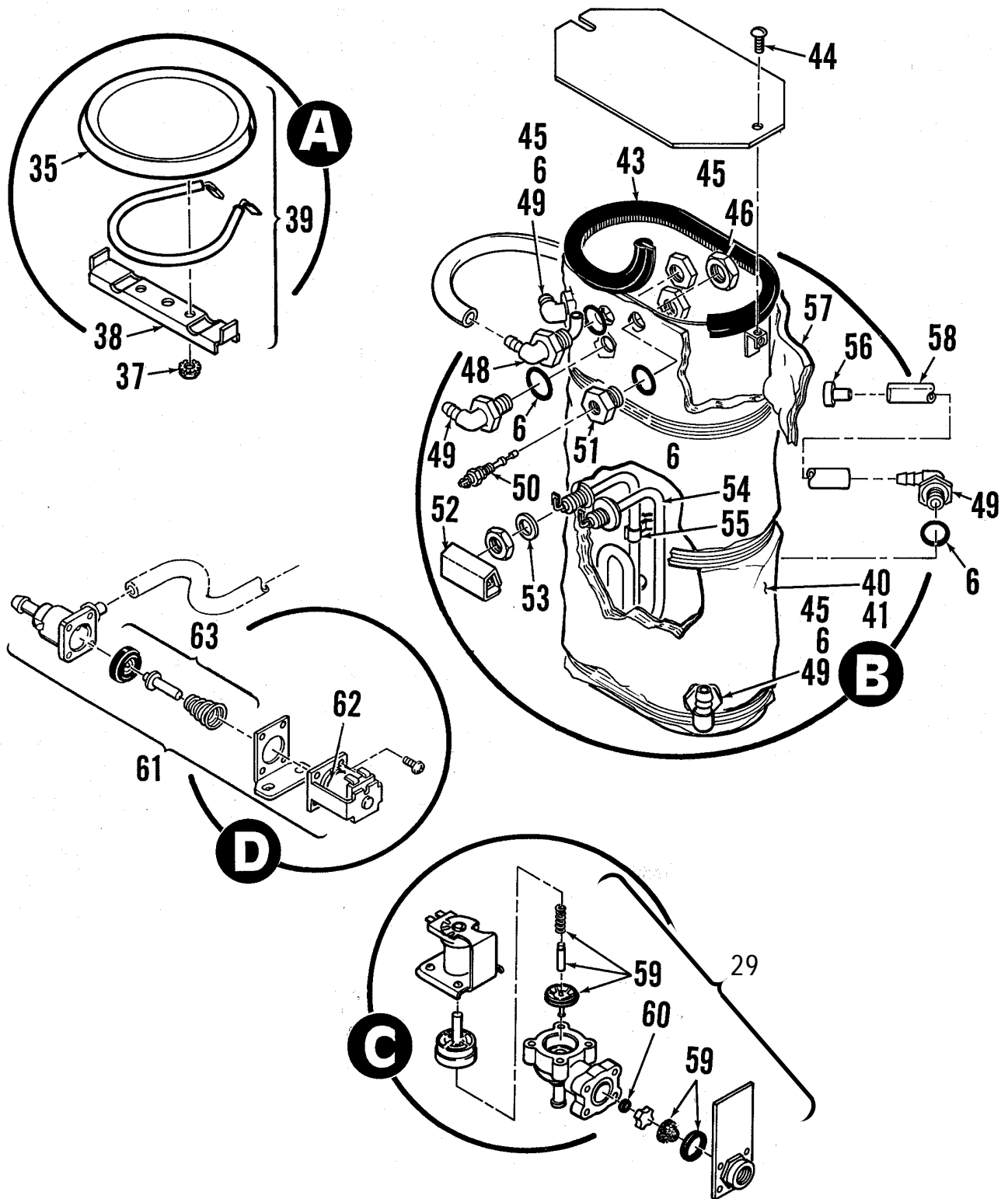

Figure 4. Illustrated Parts List, Detail Bubbles (Alpha 3X Shown).

ALPHA Parts List

INDEX NUMBER	PART NUMBER	DESCRIPTION
1	WC-38310	LABEL, "CAREFUL HOT SURFACE"
2	WC-6205	COVER, TOP WARMER DECK
3	WC- 517	THERMOSTAT
4	WC-4505	SCREW, 8-32 x 1/2 PHILLIPS
5	WC-2977	FITTING, SPRAYHEAD
6	WC-4320	O' RING
7	WC-2922	SLEEVE, BY-PASS, INCL. SCREW
8	WC- 604	TIMER, BREW
9	WC-4436	SCREW, 4x3/8 PHIL PAN HEAD
10	WC-3958	LABEL, TOP SWITCH PANEL, ALPHA 3
11	WC- 130	SWITCH, ON/OFF, WHITE
12	WC- 129	SWITCH, WARMER, RED
13	WC- 128	SWITCH, BREW, GREEN
14	WC- 202	LIGHT, BREW READY, 120V
15	WC-1809	FAUCET, HOT WATER
16	WC-1806	SEAT CUP, SILICONE
17	WC-5477	COVER, FRONT
18	WC-4213	LOCK NUT 5/8" BRASS
19	WC-2936	SPRAYHEAD, RED
20	WC-1411	BUSHING, 5/8" SNAP-IN
21	WC-5819	COVER, BOTTOM
22	WC-3621	BREW CONE, UNIVERSAL (STANDARD)
23	CR-10	FILTER PAPER, 12 CUP (BOX OF 1,000)
24	WC-3503	FOOT, RUBBER, 3/8 - 16 STUD
25	WC-1408	CORD GRIP, STRAIN RELIEF, 7/8"
26	WC-1200	POWER CORD, 120V
27	WC-2401	ELBOW, 1/4 x 3/8, FLARE
28	WC-4616	SCREW, 1/4-20x1/2 PHILLIPS PAN HEAD SS
29	WC- 826L	VALVE, INLET 1 GPM, 120V 10W
30	WC- 608	LIQUID LEVEL CONTROL BOARD
31	WC-4380	SHOCK GUARD, LLC
32	WC-4329	LOCK WASHER, EXTERNAL #8
33	WC-4525	SCREW, 8-32x1/4 PHILLIPS TRUSS HD SS
34	WC-6207	UPPER WARMER DECK UNIT
35	WC-37102	KIT, WARMER ELEMENT 100W 120V
37	WC-4201	NUT, KEP, 8-32, ZINC
38	WC-6732	STRAP FOR WARMER PLATE
39	WC-6234	WARMER PLATE ASSEMBLY (ITEM N° 35 THRU 38)
40	WC-54031	HEATING TANK WITH FITTINGS
41	WC-54032	TANK, ASSY HEATING W/FITTINGS & HTNG ELMNTS 120V
43	WC-43014	GASKET, HEATING TANK
44	WC-4543	SCREW, 8-32 x 1" SLOTTED HEX SS
45	WC-4211	NUT, 3/8" JAM
46	WC-4212	NUT, 5/8" JAM
48	WC-29015	FITTING, BARBED OVERFLOW
49	WC-29009	FITTING, BARBED INLET

ALPHA 3X Parts List

INDEX NUMBER	PART NUMBER	DESCRIPTION
50	WC-5502	PROBE, WATER LEVEL
51	WC-2938	FITTING, 1/8" HEX FOR WATER LEVEL PROBE
52	WC-4394	SHOCK GUARD FOR HEATING ELEMENT
53	WC-4306	WASHER, 9/16" I.D. TEFLON
54	WC- 917-04	HEATING ELEMENT, 120V, 1450W
55	WC-5409	CLIP, THERMOSTAT CAPILLARY
56	WC-43058	PLUG, TANK DRAIN PP RED
57	WC-3685	INSULATION, WRAP ALPHA.
58	WC-5310	TUBING, SILICONE, 5/16" I.D.
59	WC-3765L	KIT, INLET VALVE REPAIR
60	WC- 829	WASHER, FLOW
61	WC- 889	VALVE, DUMP LEFT 120V 12W
62	WC- 411	COIL FOR DUMP VALVE (WC-821)
63	WC-3763	KIT, DUMP VALVE FOR WC889

ALPHA 3XR, 3XL, 2X, 6X. PAGE 9, 10, 11.

64	WC-6206	COVER, ALPHA 3XR & 3XL TOP
65	WC-5820	COVER, ALPHA 3XR & 3XL BOTTOM
66	WC-39096	LABEL, ALPHA 3XR & 3XL SWITCH PANEL
67	WC-6224	COVER, ALPHA 2X TOP
68	WC-39039	LABEL, ALPHA 2X SWITCH PANEL
70	WC-6642	COVER, ALPHA 6X TOP
71	WC-6666	COVER, ALPHA 6X FRONT
72	WC-5895	COVER, ALPHA 6X BOTTOM

ALPHA 3XR & ALPHA 3XL

THIS FIGURE ILLUSTRATES THE DIFFERENCES BETWEEN THE ALPHA 3XR/L AND THE ALPHA 3X. THE ALPHA 3XR/L HAS A PLAIN TOP COVER AND A WIDE BOTTOM COVER. THE LABELING ON THE SWITCH PANEL IS ALSO DIFFERENT.

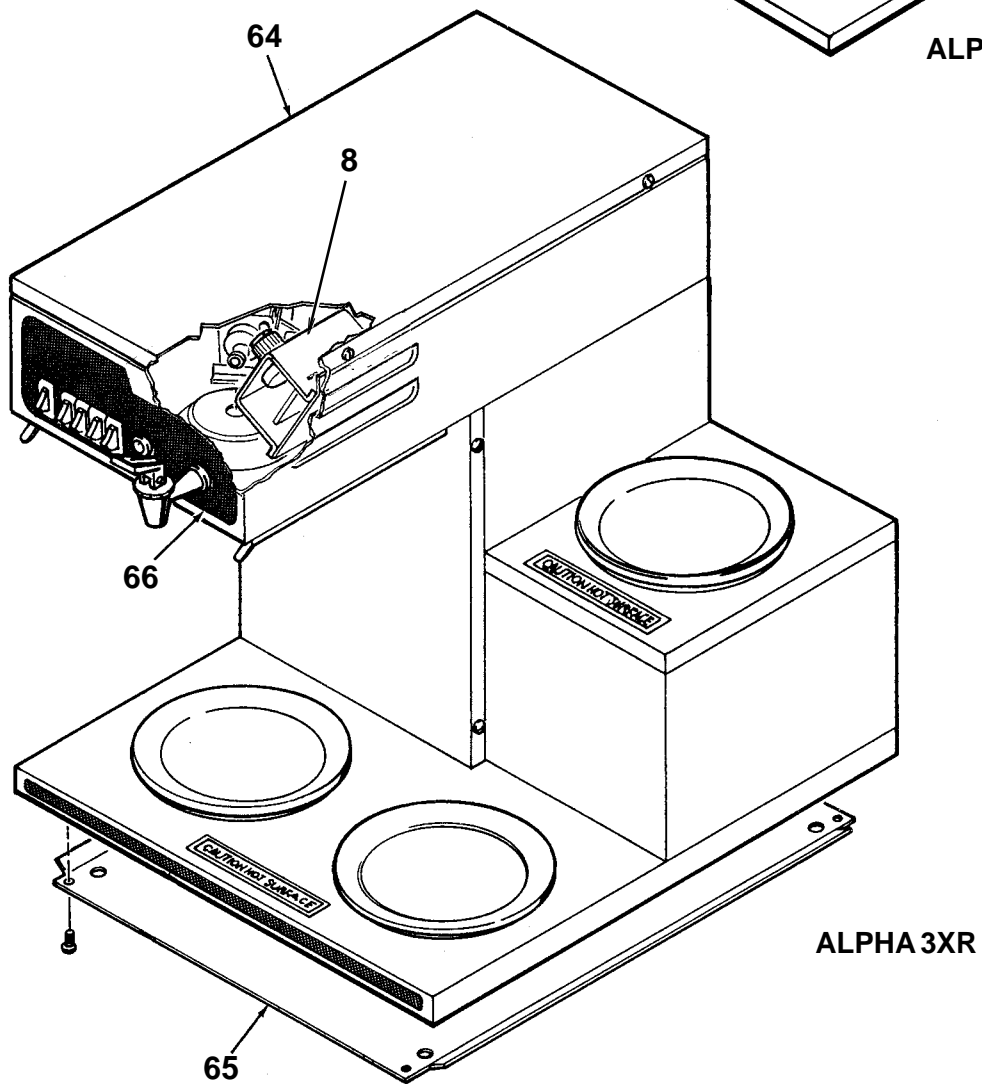
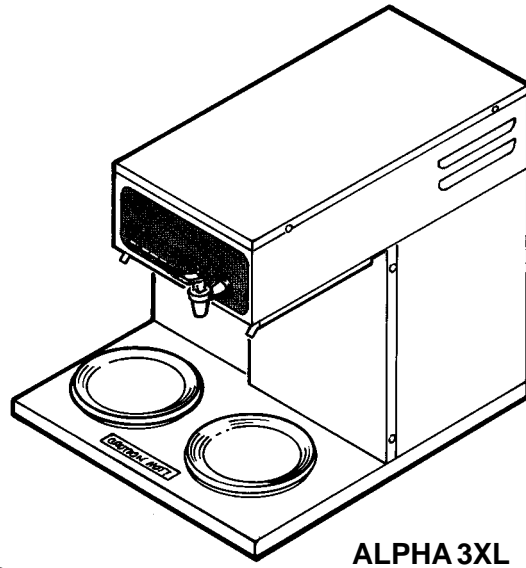

Figure 5. Illustrated Parts, Alpha 3XR & 3XL.

ALPHA 2X

THIS FIGURE ILLUSTRATES THE DIFFERENCES BETWEEN THE ALPHA 2X AND THE ALPHA 3X. THE ALPHA 2X HAS ONLY TWO WARMERS, A DIFFERENT TOP COVER AND TWO WARMER SWITCHES ON THE SWITCH PANEL.

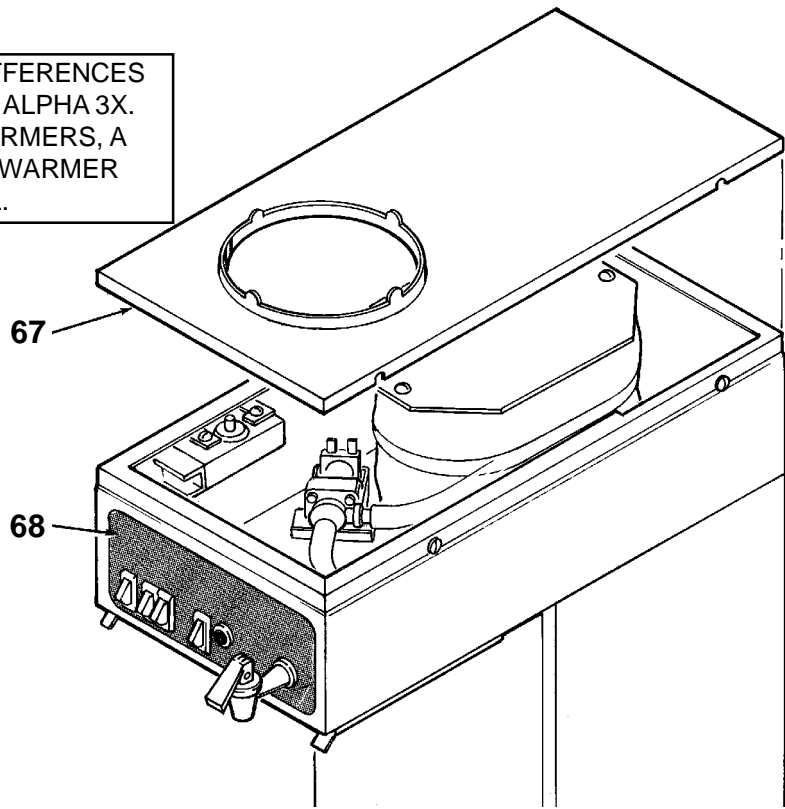

Figure 6. Illustrated Parts, Alpha 2X.

ALPHA 6X

THE ALPHA 6X IS BASICALLY AN ALPHA 3XR AND AN ALPHA 3XL LINKED TOGETHER. THIS FIGURE ILLUSTRATES THE DIFFERENCES BETWEEN THE ALPHA 6X AND THE ALPHA 3X. THE ALPHA 6X HAS A TOTAL OF SIX WARMERS, A LARGER TOP COVER, CENTER COVER, AND BOTTOM COVER.

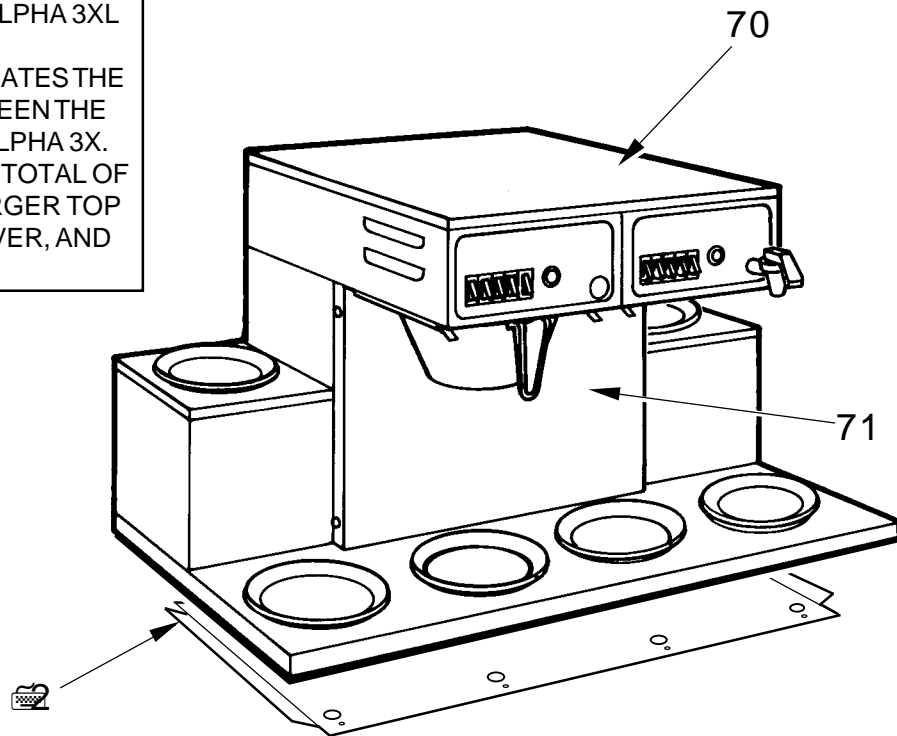

Figure 8. Illustrated Parts, Alpha 6X.

DRWN. F. Nunez	APPVD.	WIRES 2+GND	HZ 60	WIRING DIAGRAM		MODELS	ALPHA-3X -10	REV.
DATE 8/4/97		PHASE Single	VOLTS 120	AMPS 14.8	WATTS 1780		ALPHA-3XL & 3XR -10	C

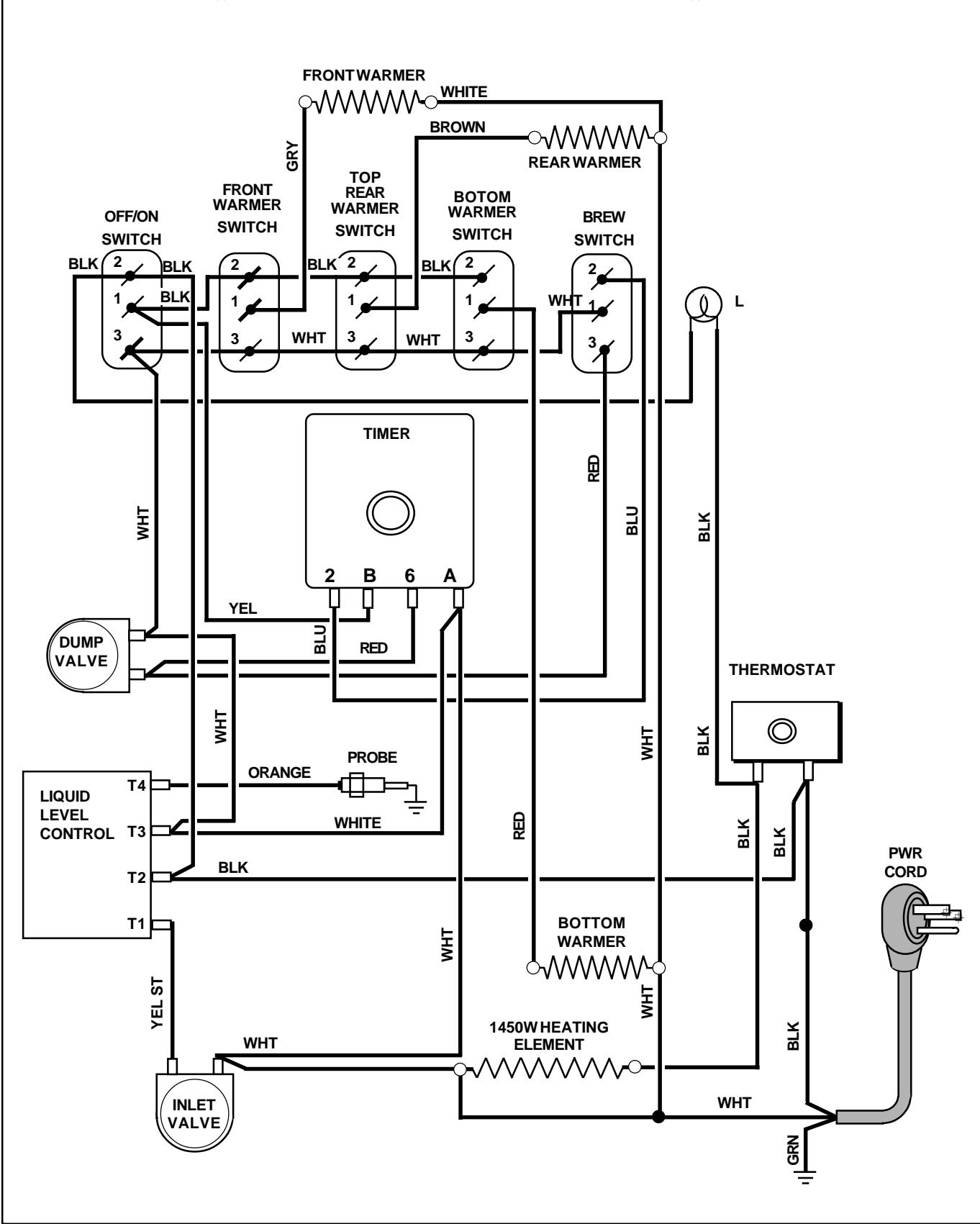

Figure 9. Alpha-3X-10, Wiring Diagram

DRWN.	APPVD.	WIRES 2+GND	HZ 60	WD-AL2X-10		MODEL	REV. C
CHKD.	DATE 8/4/97	PHASE Single	VOLTS 120	AMPS 14.2	WATTS 1700	ALPHA 2X -10	

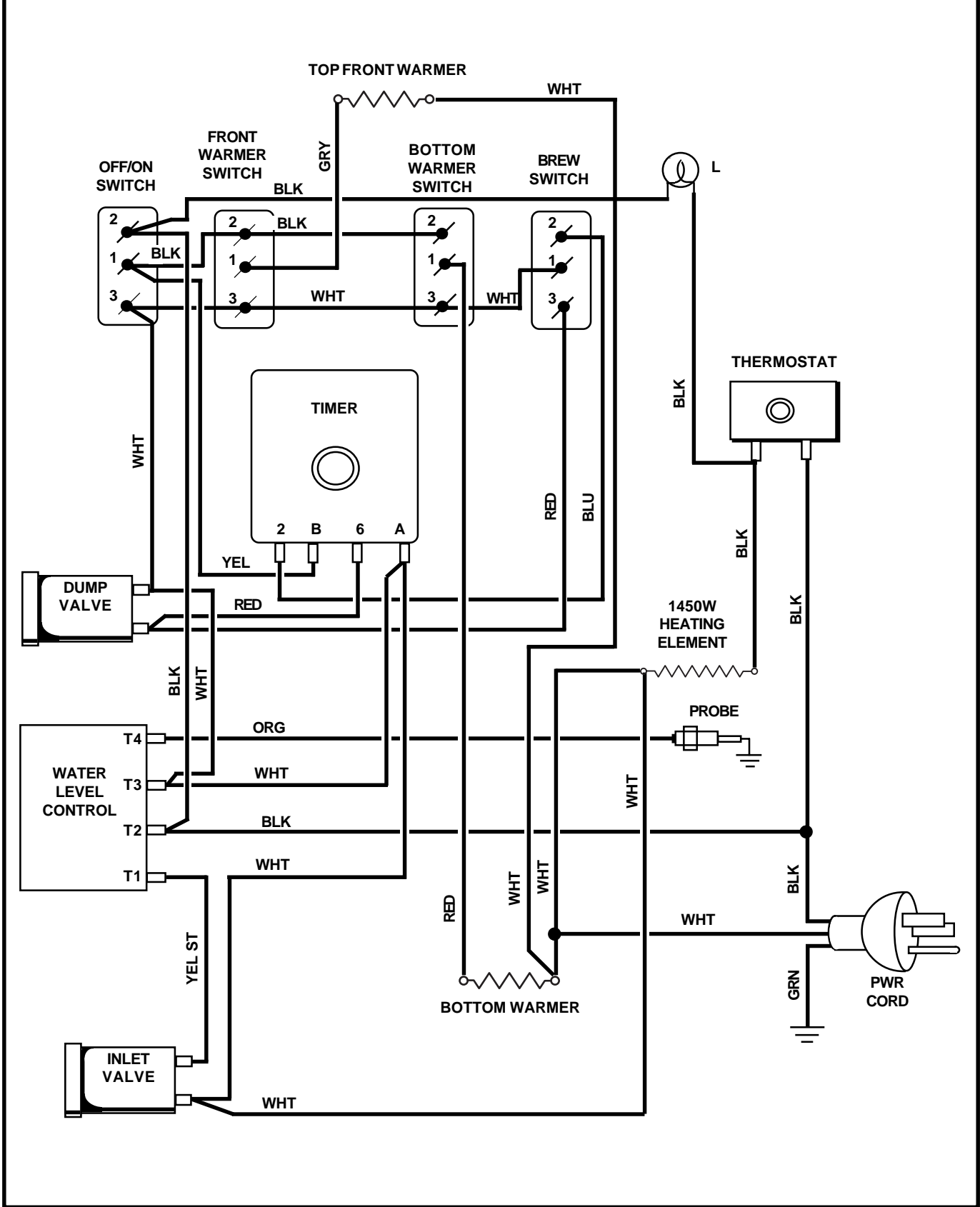

Figure 10. Alpha-2X-10, Wiring Diagram

DRWN.	APPVD.	WIRES 2+GND	HZ 60	WD-AL1X-10		MODEL	REV.
CHKD.	DATE 8/4/97	PHASE Single	VOLTS 120	AMPS 13.3	WATTS 1600	ALPHA 1X-10	B

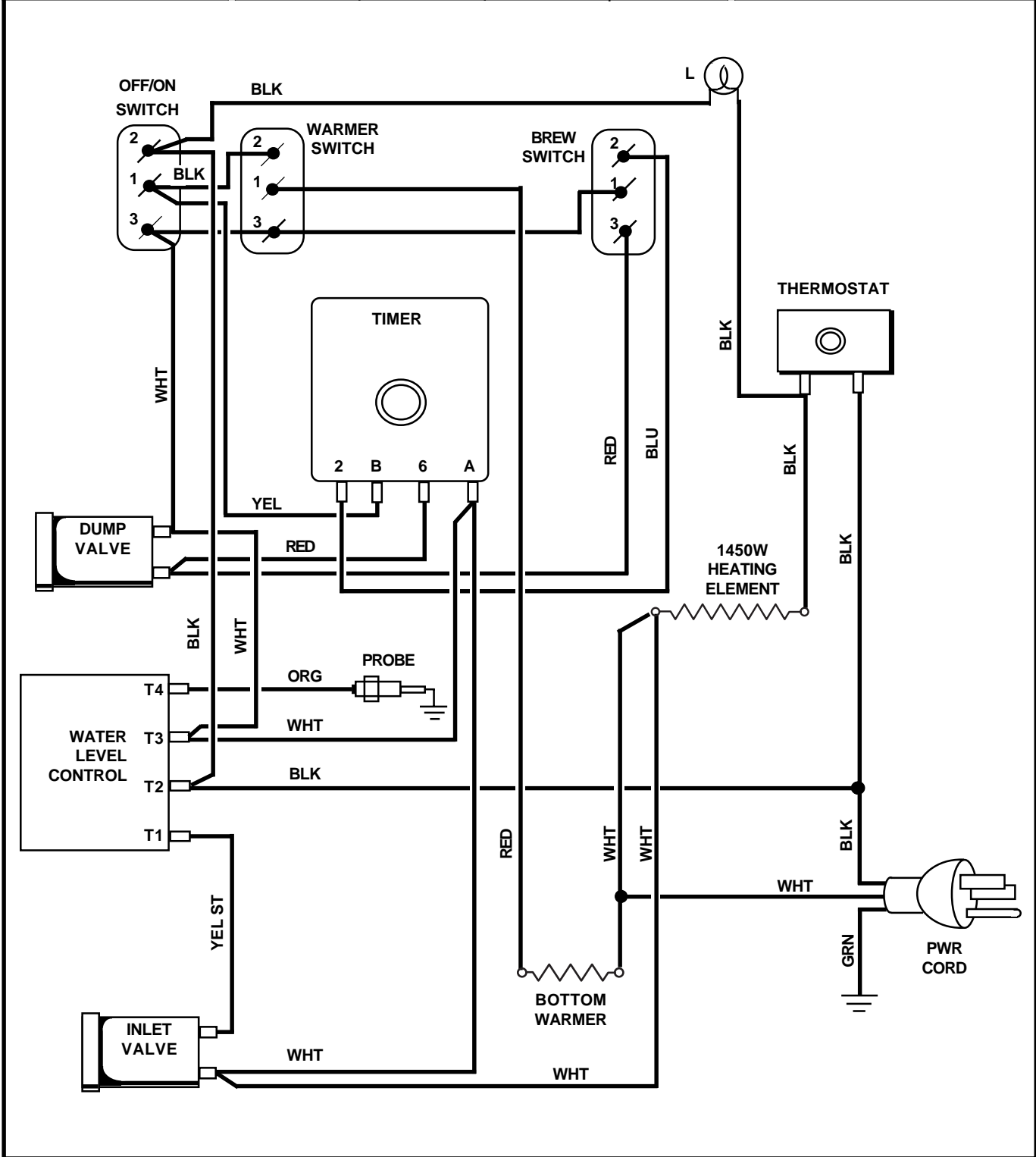

Figure 11. Alpha-1X -10, Wiring Diagram

**THIS PAGE
INTENTIONALLY
LEFT BLANK**

Product Warranty Information

The Wilbur Curtis Company certifies that its products are free from defects in material and workmanship under normal use. The following limited warranties and conditions apply:

- 3 Years, Parts and Labor, from Original Date of Purchase on digital control boards.
- 2 Years, Parts, from Original Date of Purchase on all other electrical components, fittings and tubing.
- 1 Year, Labor, from Original Date of Purchase on all electrical components, fittings and tubing.

Additionally, the Wilbur Curtis Company warrants its Grinding Burrs for Forty (40) months from date of purchase or 40,000 pounds of coffee, whichever comes first. Stainless Steel components are warranted for two (2) years from date of purchase against leaking or pitting and replacement parts are warranted for ninety (90) days from date of purchase or for the remainder of the limited warranty period of the equipment in which the component is installed.

All in-warranty service calls must have prior authorization. For Authorization, call the Technical Support Department at 1-800-995-0417. Effective date of this policy is April 1, 2003.

Additional conditions may apply. Go to www.wilburcurtis.com to view the full product warranty information.

CONDITIONS & EXCEPTIONS

The warranty covers original equipment at time of purchase only. The Wilbur Curtis Company, Inc., assumes no responsibility for substitute replacement parts installed on Curtis equipment that have not been purchased from the Wilbur Curtis Company, Inc. The Wilbur Curtis Company will not accept any responsibility if the following conditions are not met. The warranty does not cover and is void under the following circumstances:

- 1) **Improper operation of equipment:** *The equipment must be used for its designed and intended purpose and function.*
- 2) **Improper installation of equipment:** *This equipment must be installed by a professional technician and must comply with all local electrical, mechanical and plumbing codes.*
- 3) **Improper voltage:** *Equipment must be installed at the voltage stated on the serial plate supplied with this equipment.*
- 4) **Improper water supply:** *This includes, but is not limited to, excessive or low water pressure, and inadequate or fluctuating water flow rate.*
- 5) **Adjustments and cleaning:** *The resetting of safety thermostats and circuit breakers, programming and temperature adjustments are the responsibility of the equipment owner. The owner is responsible for proper cleaning and regular maintenance of this equipment.*
- 6) **Damaged in transit:** *Equipment damaged in transit is the responsibility of the freight company and a claim should be made with the carrier.*
- 7) **Abuse or neglect (including failure to periodically clean or remove lime accumulations):** *Manufacturer is not responsible for variation in equipment operation due to excessive lime or local water conditions. The equipment must be maintained according to the manufacturer's recommendations.*
- 8) **Replacement of items subject to normal use and wear:** *This shall include, but is not limited to, light bulbs, shear disks, "O" rings, gaskets, silicone tube, canister assemblies, whipper chambers and plates, mixing bowls, agitation assemblies and whipper propellers.*
- 9) **Repairs and/or Replacements** *are subject to our decision that the workmanship or parts were faulty and the defects showed up under normal use. All labor shall be performed during regular working hours. Overtime charges are the responsibility of the owner. Charges incurred by delays, waiting time, or operating restrictions that hinder the service technician's ability to perform service is the responsibility of the owner of the equipment. This includes institutional and correctional facilities. The Wilbur Curtis Company will allow up to 100 miles, round trip, per in-warranty service call.*

RETURN MERCHANDISE AUTHORIZATION: *All claims under this warranty must be submitted to the Wilbur Curtis Company Technical Support Department prior to performing any repair work or return of this equipment to the factory. All returned equipment must be repackaged properly in the original carton. No units will be accepted if they are damaged in transit due to improper packaging. **NO UNITS OR PARTS WILL BE ACCEPTED WITHOUT A RETURN MERCHANDISE AUTHORIZATION (RMA). RMA NUMBER MUST BE MARKED ON THE CARTON OR SHIPPING LABEL.** All in-warranty service calls must be performed by an authorized service agent. Call the Wilbur Curtis Technical Support Department to find an agent near you.*



WILBUR CURTIS CO., INC.
6913 Acco St., Montebello, CA 90640-5403 USA
Phone: 800/421-6150 ♦ Fax: 323-837-2410
♦ Technical Support Phone: 800/995-0417 (M-F 5:30A - 4:00P PST) ♦ E-Mail: techsupport@wilburcurtis.com
♦ Web Site: www.wilburcurtis.com