

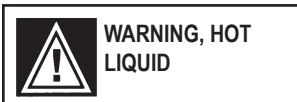

Primo Cappuccino System Instructions

Models Included

- PC-4D
- PC-3D
- PC-2D
- PC-1D
- HC-1D

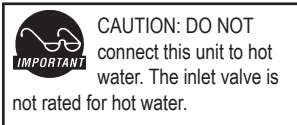
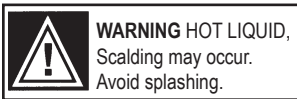

Important Safeguards/Conventions

This appliance is designed for commercial use. Any servicing other than cleaning and maintenance should be performed by an authorized Wilbur Curtis service center.

- Do NOT immerse the unit in water or any other liquid
- To reduce the risk of fire or electric shock, do NOT open top panel. No user serviceable parts inside. Repair should be done only by authorized service personnel.
- Keep hands and other items away from hot parts of unit during operation.
- Never clean with scouring powders or harsh implements.

Conventions



WARNINGS – To help avoid personal injury



Important Notes/Cautions – from the factory



Sanitation Requirements

Your Curtis ADS System is Factory Pre-Set and Ready to Go... Right from the Carton.

Following are the Factory Settings for your ALPHA™ DS Coffee Brewing Systems:

- Tank Temperature = 190°F
- Flavor Controls= Set at 100%
- Dispensing Mode Set for Manual Dispensing

Generally there will never be a reason to change your ADS programming. However, should you need to make slight adjustments to meet your brewing needs, programming instructions are provided later in this manual.

System Requirements:

- Water Source 20 – 90 PSI (Minimum Flow Rate of 1 GPM)
- Electrical: See attached schematic for standard model or visit www.wilburcurtis.com for your model.

Equipment to be installed to comply with applicable federal, state, or local plumbing/electrical codes having jurisdiction.

SETUP STEPS

The unit should be level (left to right and front to back), located on a solid counter top. Connect a water line from the water filter to the brewer. NOTE: Some type of water filtration device must be used to maintain a trouble-free operation. (In areas with extremely hard water, we suggest that a sedimentary and taste & odor filter be installed.) This will prolong the life of your brewing system and enhance coffee quality.



The National Sanitation Foundation requires the following water connection:

1. A quick disconnect or additional coiled tubing (at least 2x the depth of the unit) so that the machine can be moved for cleaning underneath.
2. In some areas an approved backflow prevention device may be required between the brewer and the water supply.

1. Connect a water line from your facility to the 1/4" flare water inlet fitting of the valve, behind the machine. Water volume going to the machine should be stable. Use tubing sized sufficiently to provide a minimum flow rate of one gallon per minute.
2. Plug the power cord into an electrical outlet rated at 20A.
3. Switch on the CONTROL switch that runs power to the components in the machine. The lights (display window & row of buttons) on the front door will activate and the heating tank will start to fill.
4. Once the water level has risen and covered the heating element, turn on the power to the heating element at the HEATING ELEMENT switch behind the unit.
5. Water in the heating tank will require about 30 minutes to reach operating temperature (factory setting of 190°F). At this time the READY light will come on.
6. Remove and fill the canisters with powdered cappuccino mixes.

OPERATION INSTRUCTIONS

1. Choose a flavor. Place your cup under the spout beneath the desired flavor.
2. Push the dispensing button for this flavor.
3. Allow the Primo Cappuccino unit time to completely dispense the product.

FILL CANISTERS DAILY

1. Open the front door to access canisters.
2. The canisters must be removed from the unit for filling. The rectangular canisters hold approximately four pounds of product. Each round cannister will hold approximately six pounds of product.
3. Reposition the canisters on the machine, aligning the gear socket with the motor shaft. The pin under the canister must align with the guide hole on the support shelf.

Control Board and Membrane Control Panel

FUNCTIONS OF THE CONTROL BOARD

- GEAR MOTOR SPEED** is a powder dispensing adjustment and is accessed by mode level no. 1 when programmed.
- PRESET DISPENSING** Product is dispensed at a measured amount when the PUSH button is pressed.
- MANUAL DISPENSING** allows the user to dispense product for as long as the PUSH button is pressed.
- STOP** will cancel a preset dispense cycle.
- WASH CYCLE** is used in conjunction with a PUSH button, to flush the whipper chambers.
- HOT WATER DISPENSING** for tea, hot chocolate or other instant beverages (available on some models, not shown).

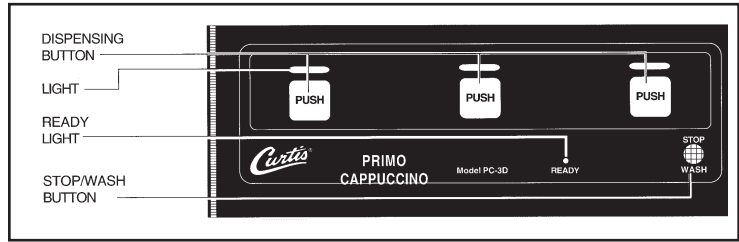

PROGRAMMING

Programming Mode PC-2D, PC-3D, PC-4D

To enter the programming mode, press and hold any two of the PUSH buttons on the membrane control panel simultaneously, until all lights start blinking. Then release the buttons and choose any mode of operations for any of the PUSH buttons. Press STOP button if both PUSH buttons were not pressed simultaneously.

Programming Mode PC-1D

To enter the programming mode, press and hold the PUSH button and the STOP/WASH button on the membrane panel simultaneously, until the indicator light starts blinking. Then release the buttons and choose any mode of operation. Press STOP/WASH button if both buttons were not pressed simultaneously.

While in the programming mode you may perform the following three functions:

- Powder Dispensing Mode.** Controls dispensing powder anywhere from 10% to 100% by volume. Press and hold the selected PUSH button for approximately one second, then release. The number of flashes represent the set volume for this button (see table). To change the volume, press and hold the button until its light starts quick flashing. Each quick flash increases the volume by 10%. Release the button when the desired volume is achieved. After releasing the button, the number of blinks represent the new setting. To exit the Powder Dispensing Mode, push one of the other PUSH buttons.
- Preset Liquid Dispensing Mode.** This mode allows you to set the time for automatic dispensing. To select or change the timing while in the programming mode, press and hold the selected PUSH button until the liquid begins to flow, then release. The timing starts when liquid begins to flow. When the desired volume is achieved, press once again to stop the dispensing. You have now set the timing for this button and have exited the programming mode. If you press the selected button, it will dispense the liquid per your setting. To reset the timing, you must start from the programming mode.
- Manual Liquid Dispensing Mode.** While you are in the programming mode, press and hold the PUSH button, until the liquid stops flowing, then release the button. At this time, you have selected the Manual Liquid Dispensing Mode and have exited the programming mode.

NO. OF FLASHES	VOLUME
1	10%
2	20%
3	30%
4	40%
↓	↓
10	100%

Wash Cycle Mode. To wash a whipping chamber, hold the STOP/WASH button and press the PUSH button. Rinse water will dispense for as long as you hold in the STOP/WASH button. The STOP/WASH button stops the dispensing in automatic dispensing mode.

HEATING ELEMENT TOGGLE SWITCH

The heating element in the heating tank may be turned off in the Primo Cappuccino to allow the operator to use the unit for cold drinks. Located behind the unit are two toggle switches. The one on the bottom is the power switch for shutting down the complete unit. The top switch powers the heating element. Flip down to turn it OFF. Up turns ON the element.

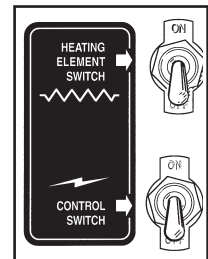

ADJUSTING THE TEMPERATURE: Factory Setting 190°

The water level/temperature circuit board, WC-3777, serves two functions. As the name implies, it is both a thermostat and water level control. This electronic board maintains the water level using a probe in the tank. Water temperature in the tank is controlled by a sensor bolted on the outside of the tank, just under the heating element terminals.

- Open the front door. Remove the hinged top cover.
- Remove the left side panel.
- Locate the water level/temperature board, on the left side of the frame.
- Near the center of the board you will find a pair of tiny 'shorting plugs' attached to two pairs of pins (see illustration, right). Just above this is a chart that displays the various combinations you may choose that will give you temperatures between 170° F and 200° F. Pull out or insert the shorting plug in any configuration that will result in the desired temperature.
- Return the side panel and cover to on the unit.

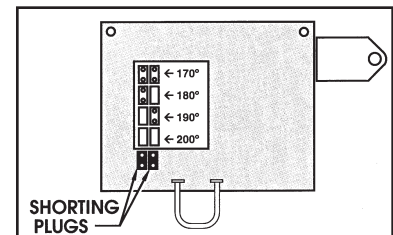

DAILY CLEANING

- Wipe all exterior surfaces with a damp cloth; removing any spills, dust or debris from the unit.
- Pull out the drip drawer and screen. Wash out its contents. For hard to clean deposits, use a mild, nonabrasive solution of dishwashing detergent and water.
- Clean around the dispensing area, wiping with a nontoxic cleaner.

PARTS DIAGRAMS

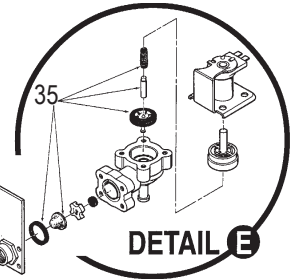
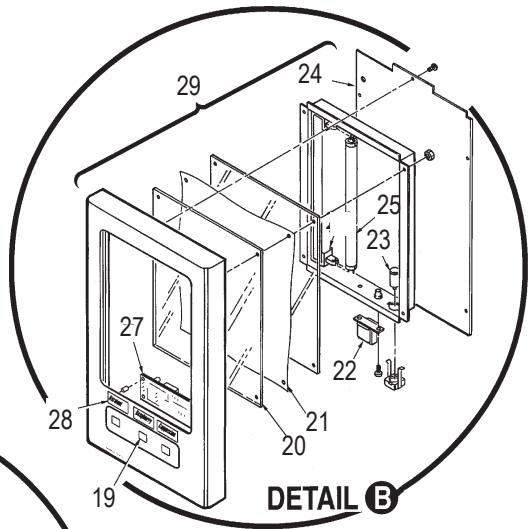
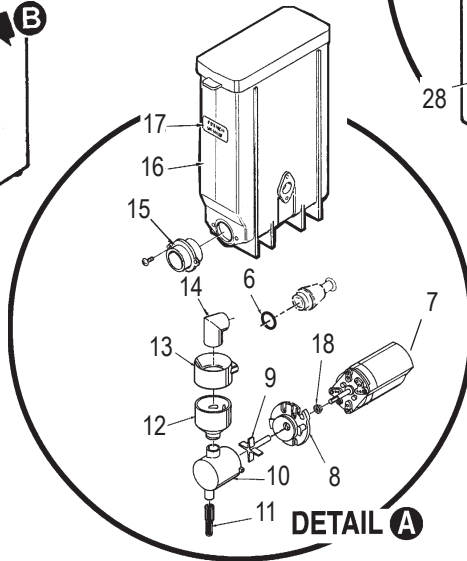
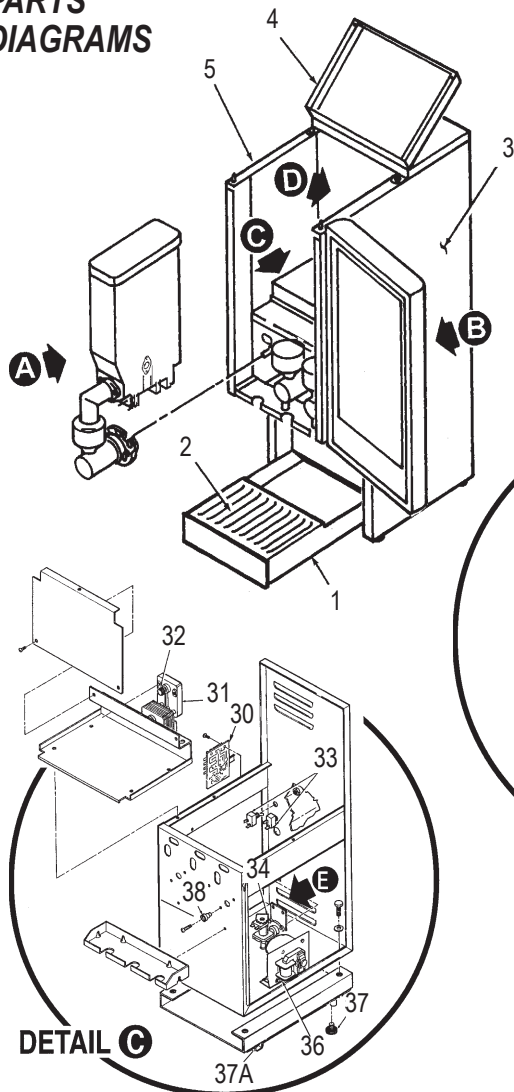

DETAIL C

DETAIL A

DETAIL B

DETAIL E

Illustrated Parts List (PC-3D Model Shown)

Nº	Part Nº	Description
1A	WC-6857	Drawer, Drip, PC-3D
1B	WC-6760	Drawer, Drip W/PC-1D, 2D, HC-1D
1C	WC-6853	Drawer, Drip, PC-4D
2A	WC-6633	Screen, Drip Drawer PC-3D
2B	WC-6758	Screen, Drip Drwr PC-1D, PC-2D, HC-1D
2C	WC-6848	Screen, Drip Drawer PC-4D
3A	WC-6644	Panel Assy, Right Side Sub-Assy PC-3D
3B	WC-6768	Wrap Right, PC-1D, PC-2D, HC-1D
4A	WC-6645	Cover Assy, Top PC-3D
4B	WC-6747	Cover, Top Front, PC-1D/2D
4C	WC-6746	Cover, Top Back, PC-1D/2D
4D	WC-58020	Cover Assy, Top PC-4D
5A	WC-6643	Panel, Left Assy, PC-3D/PC-4D
5B	WC-6744	Panel, Left PC/HC-1D, PC-2D
6	WC-43033	O' Ring, .394 I.D., .551 O.D., .075 TH
7	WC-37014	Kit, Motor WhipperRetrofit PC/CK/HC
8	WC-37118	Kit, Whipper Plate (3/pkg)
9	CA-1008-03	Propeller, Whipper PC/CK/HC
10	CA-1006-03	Chamber, Whipper PC/CK/HC
11	CA-1037B	Tube, Extension 3.48" Long Blk All PCs
12	CA-1009-03	Bowl, Mixing PC/CK/HC
13	CA-1005-03	Steam Trap, PC/CK/HC
14	CA-1026-03	Elbow, PC/CK/HC
15	CA-1065	Bushing, Discharging 4lb Canister
16A	CA-1000	Canister Assy, 4 lb., 6.7cc/sec
16B	CA-1050	Canister Assy, Round 6 lb., PC/HC-1D
17	WC-39107-02	Label, Adhesive Canister Gen Use
18	WC-43791	Ring, Motor Shaft Plastic
19A	WC-39163	Membrane Control Panel, Curtis PC-3D
19B	WC-39169	Membrane Control Panel, PC-3DHW
19C	WC-39171	Membrane Control Panel, PC-1D, HC-1D
19D	WC-39170	Membrane Control Panel, PC-2D, 2DC1
19E	WC-39206	Membrane Control Panel, PC-4D
20A	CA-1022	Window, Outer Clear PC-3D/PC-4D
20B	CA-1060	Window, Outer Clear PC/HC-1D, PC-2D
21A	CA-1023-01	Film, Std Curtis Logo PC-3D/PC-4D
21B	CA-1061-01	Film, Generic PC-1/2 Cappuccino
21C	CA-1070-01	Film, Standard Curtis HC-1D
22	CA-1015	Transformer, 120V, 60 Hz, .18 A
23	CA-1020	Starter, Fluorescent Lamp PC/CK/HC

Nº	Part Nº	Description
24	WC-5930	Panel, Door w/Assy PC/CK-3D
25	CA-1018	Lamp, Fluorescent 8W FL8CW
26	CA-1016	Holder, Fluorescent Lamp
27A	WC- 671	Control Board, 120V, PC-3D
27B	WC- 673	Control Board, 120V, PC-3DHW
27C	WC- 675	Control Board, 120V, PC-1D, HC-1D
27D	WC- 674	Control Board, 120V, PC-2D
27E	WC- 681	Control Board, 120V, PC-4D
28	WC-39105-02	Label, Flavor Low Tack Door Gen Use
29A	WC-5862	Door, Complete PC-3D
29B	WC-5823	Door, Complete PC-2D
29C	WC-5861	Door, Complete PC-4D
29D	WC-5834	Door, Complete PC-1D
30	WC-3777	Kit, Rpl Control Bd Wtr Lvl/Temp, 120/220V
31	CA-1013	Motor, Gear Assy
32	CA-1036	Gear, Plastic Use on CA-1013
33	WC- 102	Switch, Toggle 25A 125/250VAC
34	WC- 826L	Valve, Inlet 1GPM 120V 10W
35	WC-3765L	Kit, Inlet Valve Repair (Use on WC-826L)
36	WC-37123	Kit, Extract Fan 29 CFM & Bracket
37	WC-3518	Leg, Glide 3/8"-16 Stud Screw
37A	WC-3503	Leg, 3/8"-16 Stud Screw Bumper
38	CA-1024-05	Pillar, Location Black All PCs
39	WC-4320	O' Ring, 1/2" I.D.
40	WC-5502	Probe, Water Level
41	WC-4394	Guard, Shock, Heating Element
42	WC- 904-04	Element, Heat 1.6Kw, 120V W/Jam Nuts
43	WC-5851	Cover Tank w/Notches
44	WC-3688	Insulation, Wrap PC-3/3D & PC-4/4D
44A	WC-3690	Insulation, Wrap PC-1/1D & PC-2/2D
45	CA-1039	O' Ring, Dump Valve (WC-880)
46	WC-3734	Kit, Rpl Dump Valve (WC-880E)
47	WC-43062	Gasket, Tank Lid
48A	WC-54102	Heating Tank Complete PC-3D
48B	WC-54101	Heating Tank Complete PC-2D
48C	WC-54100	Heating Tank Complete PC-1D
49	WC-6188	Heat Sink Assy, PC-3D
50	WC-1438	Sensor, Heating Tank
51	WC-5231	Compound, Silicone 5 oz. Tube

DETAIL D

ELECTRICAL SCHEMATIC

PC-3D-10

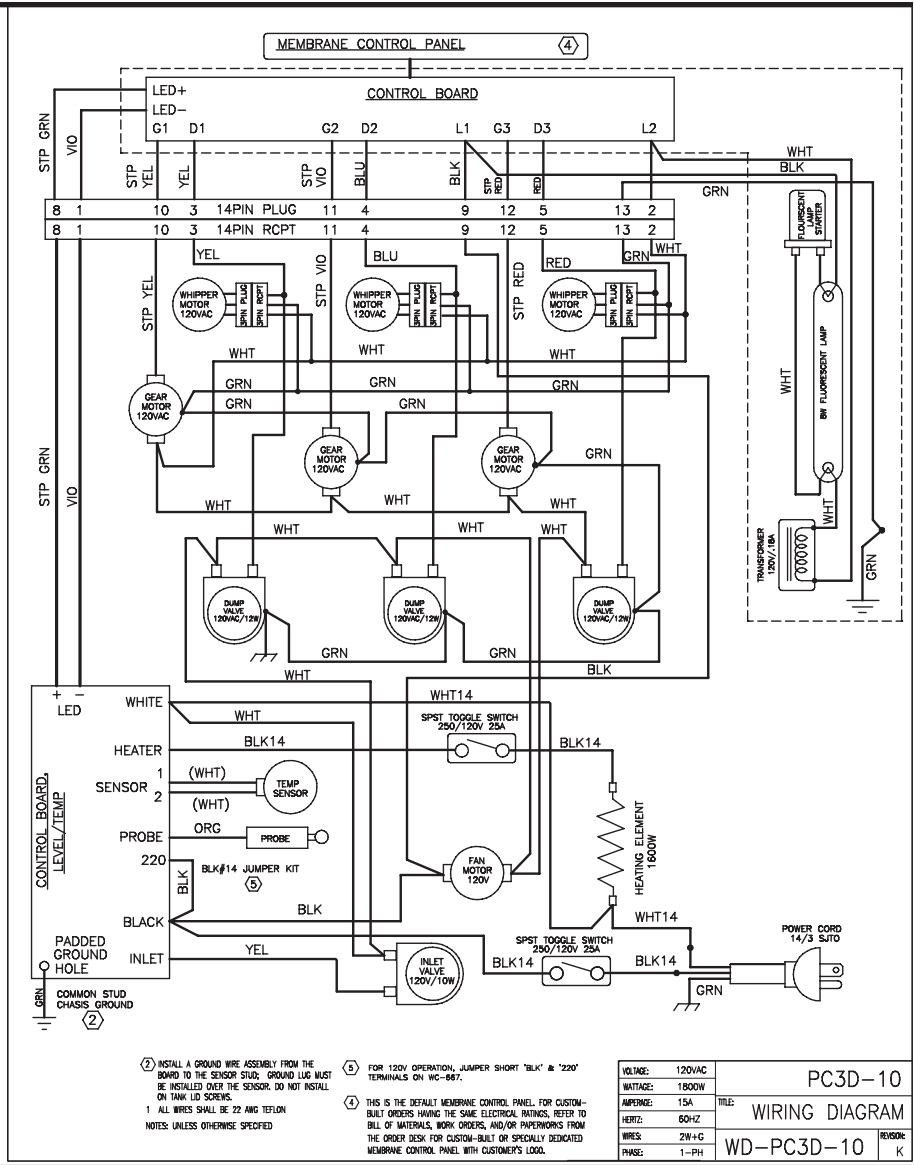

② INSTALL A GROUND WIRE ASSEMBLY FROM THE BOARD TO THE SENSOR STUD. GROUND LUG MUST BE INSTALLED OVER THE SENSOR. DO NOT INSTALL ON TANK LID SCREWS.
 ③ FOR 120V OPERATION, "JUMPER SHORT BLK" & "220" TERMINALS ON WC-667.
 ④ THIS IS THE DEFAULT MEMBRANE CONTROL PANEL. FOR CUSTOM-BUILT ORDERS HAVING THE SAME ELECTRICAL RATINGS, REFER TO BILL OF MATERIALS, WORK ORDERS, AND/OR PAPERWORKS FROM THE ORDER DESK FOR CUSTOM-BUILT OR SPECIALLY DESIGNATED MEMBRANE CONTROL PANEL WITH CUSTOMER'S LOGO.
 1 ALL WIRES SHALL BE 22 AWG TEFELON
 NOTES: UNLESS OTHERWISE SPECIFIED

VOLTAGE:	120VAC	PC3D-10
WATTAGE:	1800W	
AMPERE:	15A	TITLE: WIRING DIAGRAM
HERTZ:	60-HZ	
WIRES:	2W+G	WD-PC3D-10
PHASE:	1-PH	
		REVISION: K

WARRANTY

We hereby certify that the products manufactured by the Wilbur Curtis Company, Inc., are, to the best of our knowledge, free from all defects and faulty workmanship.

The following warranties and conditions are applicable:

- 90 Days for Labor and 1 Year Parts from Date of Purchase from Factory: This warranty covers all electrical parts, fittings and tubing.
- 40 Months or 40,000 Pounds of Coffee on a set of Grinding Burrs. (ADS Grinders)
- 2 Years from Date of Purchase: This warranty covers electronic control boards and leaking or pitting of a stainless steel body of a Brewer or Urn.
- 90 Days from Date of Purchase: On replacement parts that have been installed on out of warranty equipment

All in-warranty service calls must have prior authorization from the manufacturer. For an RMA (Return Merchandise Authorization) number, call the Technical Service Department at 1-800-995-0417. The Wilbur Curtis Company will allow up to 100 miles, round trip, per in-warranty service call.

CONDITIONS & EXCEPTIONS

The warranty covers original equipment at time of purchase only. The Wilbur Curtis Company, Inc., assumes no responsibility for substitute replacement parts installed on Curtis equipment that have not been purchased from the Wilbur Curtis Company, Inc. The Wilbur Curtis Company will not accept any responsibility if the following conditions are not met. The warranty does not cover and is void under these circumstances:

- 1) Improper operation of equipment. The equipment must be used for its designed and intended purpose and function.
- 2) Improper installation of equipment. This equipment must be installed by a professional, certified technician and must comply with all local electrical, mechanical and plumbing codes.
- 3) Wilbur Curtis Company will not be responsible for the operation of equipment at other than the stated voltages on the serial plate.
- 4) Abuse or neglect (including failure to periodically clean or remove lime accumulations). Manufacturer is not responsible for variation in equipment operation due to excessive lime or local water conditions.
- 5) Replacement of items subject to normal use and wear. This shall include, but is not limited to, light bulbs, shear disks, "O" rings, gaskets, canister assemblies, whipper chambers and plates, mixing bowls, agitation assemblies and whipper propellers.
- 6) Any faults resulting from inadequate water supply. This includes, but is not limited to, excessive or low water pressure, and inadequate or fluctuating water flow rate.
- 7) All repairs and/or replacements are subject to our decision that the workmanship or parts were faulty and the defects showed up under normal use.
- 8) All labor shall be performed during regular working hours. Overtime charges are the responsibility of the owner.
- 9) Charges incurred by delays, waiting time, or operating restrictions that hinder the service technician's ability to perform service is the responsibility of the owner of the equipment. This includes institutional and correctional facilities.
- 10) All claims under this warranty must be submitted to the Wilbur Curtis Company Technical Service Department before return of the unit to the factory.
- 11) All equipment returned to us must be repackaged properly in the original carton. No units will be accepted if they are damaged in transit due to improper packaging.
- 12) Damaged in transit.
- 13) The resetting of safety thermostats and circuit breakers, programming and temperature adjustments are the responsibility of the equipment owner.

NO UNITS OR PARTS WILL BE ACCEPTED WITHOUT A RETURN MERCHANDISE AUTHORIZATION (RMA). RMA NUMBER MUST BE MARKED ON THE CARTON OR SHIPPING LABEL.

All in-warranty service calls must be performed by an authorized service center, where service is available. Call the factory for location near you.



WILBUR CURTIS CO., INC.

6913 Acco St., Montebello, CA 90640-5403 USA

Phone: 800/421-6150 ♦ Fax: 323-837-2410

♦ Technical Support Phone: 800/995-0417 (M-F 5:30A - 4:00P PST) ♦ E-Mail: techsupport@wilburcurtis.com

♦ Web Site: www.wilburcurtis.com

Printed in U.S.A. 11/06 F-2067-S Rev B