



Gemini Digital Brewers – Instructions

Important Safeguards/Conventions

This appliance is designed for commercial use. Any servicing other than cleaning and maintenance should be performed by an authorized Wilbur Curtis service center.

- Do NOT immerse the unit in water or any other liquid
- To reduce the risk of fire or electric shock, do NOT open top panel. No user serviceable parts inside. Repair should be done only by authorized service personnel.
- Keep hands and other items away from hot parts of unit during operation.
- Never clean with scouring powders, bleach or harsh implements.

Conventions



WARNINGS – To help avoid personal injury



Important Notes/Cautions – from the factory



Sanitation Requirements

Your Curtis ADS System is Factory Pre-Set and Ready to Go... Right from the Carton.

Following are the Factory Settings for your interLock Coffee Brewing Systems:

- **Brew Temperature** = 200°F
- **Water Bypass** = On for 36 cup only
- **Brew Volume** = Set to 36 cup vessel requirements.
- **Sleep Mode** = Off

System Requirements:

- **Water Source** 20 – 90 PSI (Minimum Flow Rate of 1 GPM)
- **Electrical:** See attached schematic for standard model or visit www.wilburcurtis.com for your model.

SETUP STEPS

The unit should be level (left to right and front to back), located on a solid counter top. Connect a water line from the water filter to the brewer. NOTE: Some type of water filtration device must be used to maintain a trouble-free operation. (In areas with extremely hard water, we suggest that a sedimentary and taste & odor filter be installed.) This will prolong the life of your brewing system and enhance coffee quality.



The National Sanitation Foundation requires the following water connection:

1. A quick disconnect or additional coiled tubing (at least 2x the depth of the unit) so that the machine can be moved for cleaning underneath.
2. In some areas an approved backflow prevention device may be required between the brewer and the water supply.

1. A 3/8" NPT x 1/4" Flare elbow has been supplied for water line connection. Use tubing sized sufficiently to provide a minimum of 1.0 GPM.
2. To hookup the InterLock grinder, Locate the jack labeled "Class 2 Wiring Only" on brewer and grinder. Connect the two with the cable plug.
3. Connect the unit to an appropriate electrical power circuit.
4. Turn on the toggle (STANDBY/ON) switch behind the unit. The heating tank will start to fill. When the water level in the tank rises to the correct volume, the heating elements will energize automatically. With ADS Systems there is no danger of element burnout caused by an empty tank.
5. The heating tank will require 20 to 30 minutes to reach operating temperature (200°F) as indicated by the READY-TO-BREW indicator.
6. Prior to brewing, dispense 12 ounces of hot water through the hot water faucet.
7. Brew a cycle of at least 12 ounces, to purge the water lines of any air that may be trapped after filling.

BREWING INSTRUCTIONS

1. Brewer should be ON (Confirm at rear toggle switch, then press the ON/OFF button). Ready-to-Brew should be ON. If connected to an InterLock grinder, grinder should be on. If Interlocked, grind coffee at this time.
2. Place an empty Satellite on the warmer deck, under the brewcone and press the warmer switch.



3. Place a clean filter into the brewcone.



4. Fill brewcone with ground coffee.

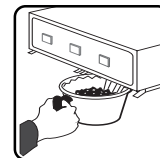

5. Transfer filled brewcone to brewer.

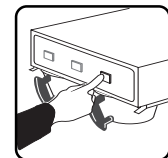

6. Press Brew button. Brewing will begin immediately.

Models Included

- ◆ GEM-612ILD
- ◆ GEM-600ILD
- ◆ TL-9002
- ◆ TL-9001



WARNING HOT LIQUID.
Scalding may occur.
Avoid splashing.



CAUTION: Please use this setup procedure before attempting to use this brewer. Failure to follow the instructions can result in injury or the voiding of the warranty.



IMPORTANT: Equipment to be installed to comply with applicable federal, state, or local plumbing/electrical codes having jurisdiction.



CAUTION: DO NOT connect this brewer to hot water. The inlet valve is not rated for hot water.



WARNING TO AVOID SCALDING. Do not remove brewcone while brew light is flashing.



ISO 9001 REGISTERED

WILBUR CURTIS COMPANY
Montebello, CA 90640

STEPS TO PROGRAMMING

WARNING These steps involve working with hot water. Scalding may occur if care is not taken against spilling.

NOTE: For ALL functions you must first enter the programming mode.

PROGRAMMING ONLY REQUIRED IF FACTORY SETTINGS MUST BE CHANGED

IMPORTANT – Before entering the program mode, allow the unit to reach brewing temperature, then press the BREW button to dispense at least 12 ounces of water to clear any air within the water lines.

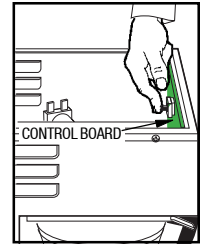

Program Tamper Switch

To enable programming, turn on the Program Switch on the control board (See illustration, right). On the Gem-612 & TL9002 DOWN is on. On the Gem-600 & TL9001 Left (while facing unit) is on. Upon completion of programming, the switch can be returned to its normal (tamperproof) position or allowed to remain in the on position.

Brew Temperature – Factory Pre-Set to 200°F

Function to set brew temperature, 170° to 204°F. Brew temperature will be indicated by READY-TO-BREW light blinking.

ENTERING THE PROGRAM MODE #1

- Turn OFF the power from the Control Panel by pressing .
- Press and HOLD and press and RELEASE .
- Continue HOLDING until starts blinking; RELEASE.

CONFIRM/RESET BREW TEMPERATURE - Factory Preset to 200°

ENTER THE PROGRAMMING MODE #1:

- Press for two seconds, then RELEASE.
- will start blinking. Each blink equals 2° F, starting at 170°.
- To change Temperature, press and HOLD .
- will start QUICK flashing. Each QUICK flash equals 2° F. After reaching 204°, temperature starts over at 170°.
- RELEASE when the desired temperature is reached.
- To set and exit, press .

BREW VOLUME - Factory Preset to Brewer Requirements

CHANGE BREW VOLUME

ENTER THE PROGRAMMING MODE #1

- Press and HOLD until hot water starts running from sprayhead (for LARGE brew, continue holding until you hear the second, by-pass valve, open) then RELEASE.
- When desired volume is reached, press again to stop flow.
- To set and exit, press .

BREW CYCLE COUNTER

ENTER THE PROGRAM MODE #2

- Turn OFF the power from the Control Panel by pressing .
- Press and HOLD and press and RELEASE .
- Continue HOLDING until STOPS blinking; RELEASE.

TO ACCESS BREW CYCLE COUNTER

ENTER THE PROGRAMMING MODE #2:

- will now start a pattern of LONG and SHORT blinks. This pattern identifies the number of brew cycles. SHORT blinks indicate the brew number from one [1] to nine [9]. LONG blinks separate the 1's, 10's, 1,000's and 10,000's.

SLEEP MODE (220V Models Only) – Factory Preset to Disabled

This function conserves energy by automatically reducing tank temperature to 140° F when the unit sits idle for more than two hours. To recover, simply press any BREW (or Grind button if InterLocked) or ON/OFF button. Once the water in the tank reaches brewing temperature, the brew cycle will automatically start. Recovery is indicated by a yellow RECOVERY light on the membrane control panel. Recovering from a SLEEP mode is faster and more efficient than heating after switching off the power.

SLEEP MODE – Factory Preset to DISABLED

To ENABLE Sleep Mode:

- UNIT MUST BE ON. Press and HOLD until turns ON; press again. Sleep Mode is now ENABLED.

To DISABLE Sleep Mode:

- UNIT MUST BE ON. Press and HOLD until turns OFF; press again. Sleep Mode is now ENABLED.

WARMERS (Gemini Only)

Adjusting the Temperature

Gemini Warmers feature three temperature settings. Warmers are rated at 90W with High (100%); Med (60%); Low (30%). Pressing the WARMER button once will place it on HIGH; A second time MED; Third time LOW as indicated by the warmer lights. A fourth press of the warmer button turns off the warmer. When the system is turned off at the ON/OFF button, it will remember the last warmer setting. Additionally, if the warmer is off, the unit is designed to automatically turn the warmer on (MED setting) when the BREW button is pressed.

To Determine Warmer Setting and Change Time:

- WARMER MUST BE OFF. Press and HOLD until the light comes ON and goes OFF; RELEASE.
- The light will start blinking. Count the blinks. Each blink=20 minutes (maximum 200 min.).
- At the end of the cycle, press and HOLD until the light begins QUICK flashing. The cycle will start over after 11 flashes (Note - A setting of 11 flashes is the OFF position).
- When the desired time is reached, RELEASE .
- To set and exit, press .

BYPASS FLOW ADJUSTMENT

1. Slide brew cone out to expose bypass outlet. Place one measuring cup under the bypass fitting, and another measuring cup under the brew cone outlet. Press the LARGE brew button for 15 seconds, then press the ON/OFF button to stop the brew cycle.
2. Divide the number of ounces collected from the bypass outlet into the total ounces collected from the sprayhead and bypass. This will determine the percentage of bypass.
3. To increase or decrease the volume of bypass water, turn the adjustment screw on the bypass valve as indicated. Clockwise for less water; counterclockwise for more water.
4. You must reprogram the brew volume to maintain the proper total amount of coffee brewed into the insulated server. Reprogramming is required every time you make a bypass adjustment or change to a different sprayhead.

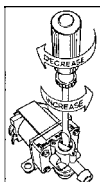

PARTS DIAGRAMS

Gem-612ILD & TL9002

All parts shown are interchangeable between the Gem-612ILD and the TL9002, except where noted.

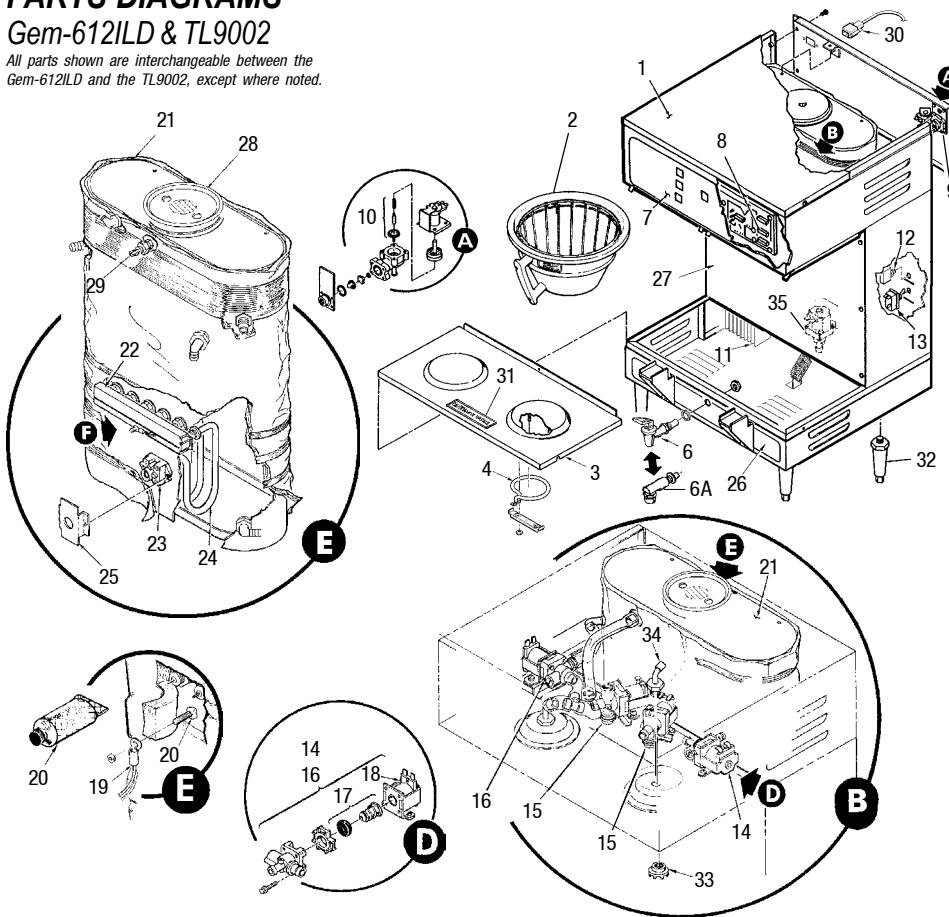

Nº	Part Nº	Description
1	WC-5421	COVER, TOP
2	WC-3357	BREWCONE W/HANDLE GEM-612ILD
2A	WC-3354	BREWCONE, GOURMET LG CAP TL9002
3	WC-5423	DECK ASSY, GEM-612ILD
3A	WC-54081	DECK ASSY, TL9002
4	WC-37102**	KIT, WARMER ELEMENT, GEM-612ILD
5	WC-6221	GRID, DRIP TRAY TL9002 (NOT SHOWN)
6	WC-1809 **	FAUCET, HOT WATER
6A	WC-2912BK**	SPOUT, HOT WATER NO SPLASH *
7	WC-39196-101	MEMBRANE CNTL PAN NO HW GEM-612
7A	WC-39196**	MEMBRANE CONTROL PANEL, GEM-612*
7B	WC-39222**	MEMBRANE CONTROL PANEL, TL9001
8	WC- 619 **	CONTROL BOARD
9	WC- 847 **	VALVE, INLET
10	WC-3765L**	KIT, VALVE REPAIR
11	WC-8560 **	HEAT SINK, 1PH GEM
12	WC-1501	FUSE HOLDER ASSY W/5A FUSE
13	WC- 102 **	SWITCH, TOGGLE
14	WC-37122 **	KIT, DUMP VALVE RIGHT
15	WC-37130 **	KIT, VALVE BY-PASS
16	WC-37121 **	KIT, DUMP VALVE LEFT
17	WC-3766 **	KIT, DUMP VALVE EATON REPAIR
18	WC- 419 **	COIL DUMP VALVE 115V EATON
19	WC-1438-101**	SENSOR, HEATING TANK
20	WC-5231 **	COMPOUND, SILICONE
21	WC-54005	TANK ASSY, COMPLETE
22	WC-4382	GUARD, SHOCK HEATING ELEMENTS
23	WC- 522 **	THERMOSTAT, RESET
24	WC- 906-04**	HEATING ELEMENT ASSY
25	WC-43055	GUARD, SHOCK RESET THERMOSTAT
26	WC-39198	LABEL, BOTTOM GEM-612ILD
27	WC-5829	COVER, FRONT GEM-612ILD
27A	WC-58014	COVER, CENTER WRAP TL9002
28	WC-37008 **	KIT, TANK LID
29	WC-5502 **	PROBE ASSY, WATER LEVEL
30	WC-1467	CABLE, 8' INTERLOCK
31	WC-38310	LABEL, CAUTION HOT SURFACE GEM-612
32	WC-3500 **	LEG, 4" ADJUSTABLE
33	WC-2936 **	SPRAYHEAD, RED PLASTIC (.131 DIA)
34	WC-2977-01	FITTING ASSY, SPRAYHEAD
35	WC- 888 **	VALVE, HOT WATER *

Gem-600ILD & TL9001

All parts shown are interchangeable between the Gem-600ILD and the TL9001, except where noted.

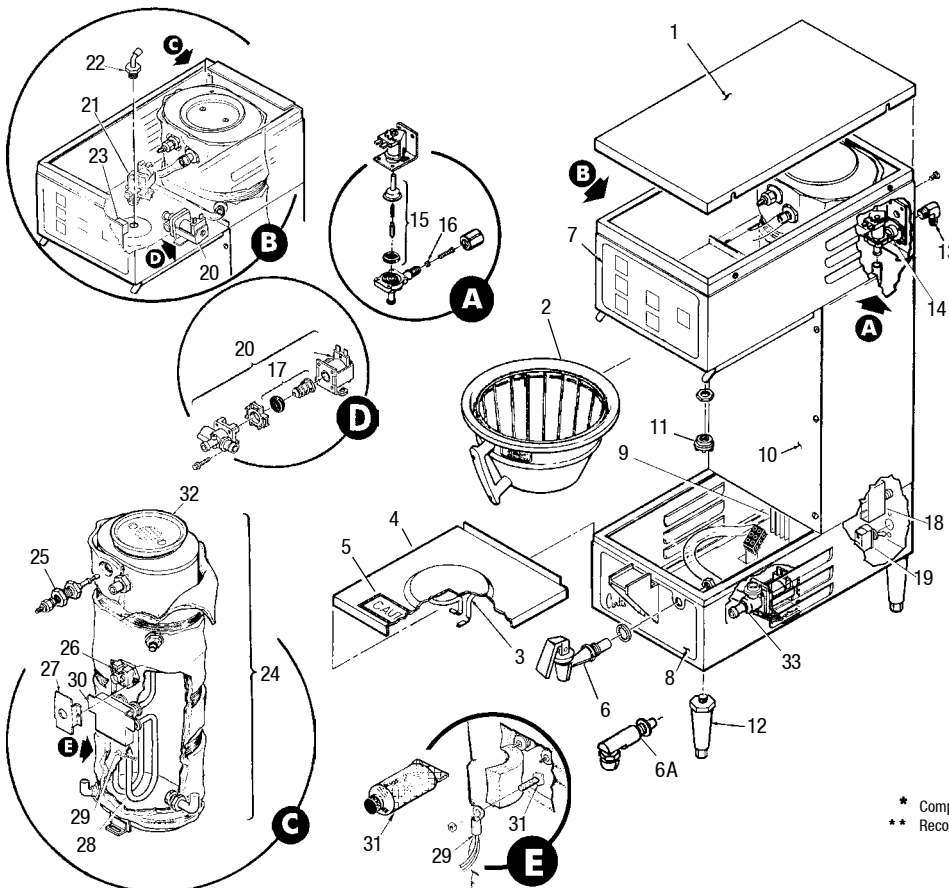

Nº	Part Nº	Description
1	WC-5450	COVER, TOP
2	WC-3357	BREWCONE ASSY COMPLETE GEM-600ILD
2A	WC-3354	BREWCONE, GOURMET LG CAP TL9001
3	WC-37102	WARMER ELEMENT GEM-600ILD
4	WC-61133	WARMER DECK GEM-600ILD
5	WC-38310	LABEL, CAUTION HOT SURFACE
6	WC-1809 **	FAUCET, HOT WATER
6A	WC-2912BK**	HOT WATER SPOUT ASSEMBLY *
7	WC-39235-101	MEMBRANE CNTL PNL, NO HW GEM-600ILD
7A	WC-39235 **	MEMBRANE CONTROL PANEL, GEM-600ILD *
7B	WC-39232 **	MEMBRANE CONTROL PANEL, TL9001
8	WC-39290	LABEL, BOTTOM PANEL
8A	WC-58018	COVER, CENTER TL9001
9	WC-2936 **	SPRAYHEAD, RED
10	WC-3500	LEG, 4" ADJUSTABLE
10A	WC-58018	COVER, CENTER TL9001
11	WC-2936 **	SPRAYHEAD, RED
12	WC-3500	LEG, 4" ADJUSTABLE
13	WC-2805	FITTING, ELBOW COMPRESSOR 3/8" x 3/8"
14	WC- 827 **	VALVE, WATER INLET
15	WC-3700 **	KIT, VALVE REPAIR FOR WC-827
16	WC- 830 **	WASHER, FLOW 1 GPM FOR WC-827
17	WC-3766 **	KIT, DUMP VALVE EATON REPAIR
18	WC-1501	FUSE HOLDER ASSY W/5A FUSE
19	WC- 102 **	SWITCH, TOGGLE 125V, 80A
20	WC-37122**	KIT, DUMP VALVE RIGHT
21	WC-37121**	KIT, DUMP VALVE LEFT
22	WC-2977-01	FITTING ASSY, SPRAYHEAD
23	WC- 679 **	CONTROL BOARD, GEM-600ILD/TL-9001
24	WC-61031	HEATING TANK COMPLETE
25	WC-5502-01	PROBE ASSY, WATER LEVEL
26	WC- 522	THERMOSTAT, RESET
27	WC-43055	SHOCK GUARD, RESET THERMOSTAT
28	WC- 906-04**	HEATING ELEMENT ASSY, 2000W 220V
29	WC-1438 **	SENSOR HEATING TANK
30	WC-43801	SHOCK GUARD, HEATING ELEMENTS
31	WC-5231 **	COMPOUND, SILICONE 3/4 OZ TUBE
32	WC-37008	KIT, TANK LID
33	WC- 888 **	VALVE, HOT WATER *

* Components used on earlier Gemini models, equipped with electric faucets.
 ** Recommended parts to stock.

Electrical Schematic

Gem-612ILD & TL-9002

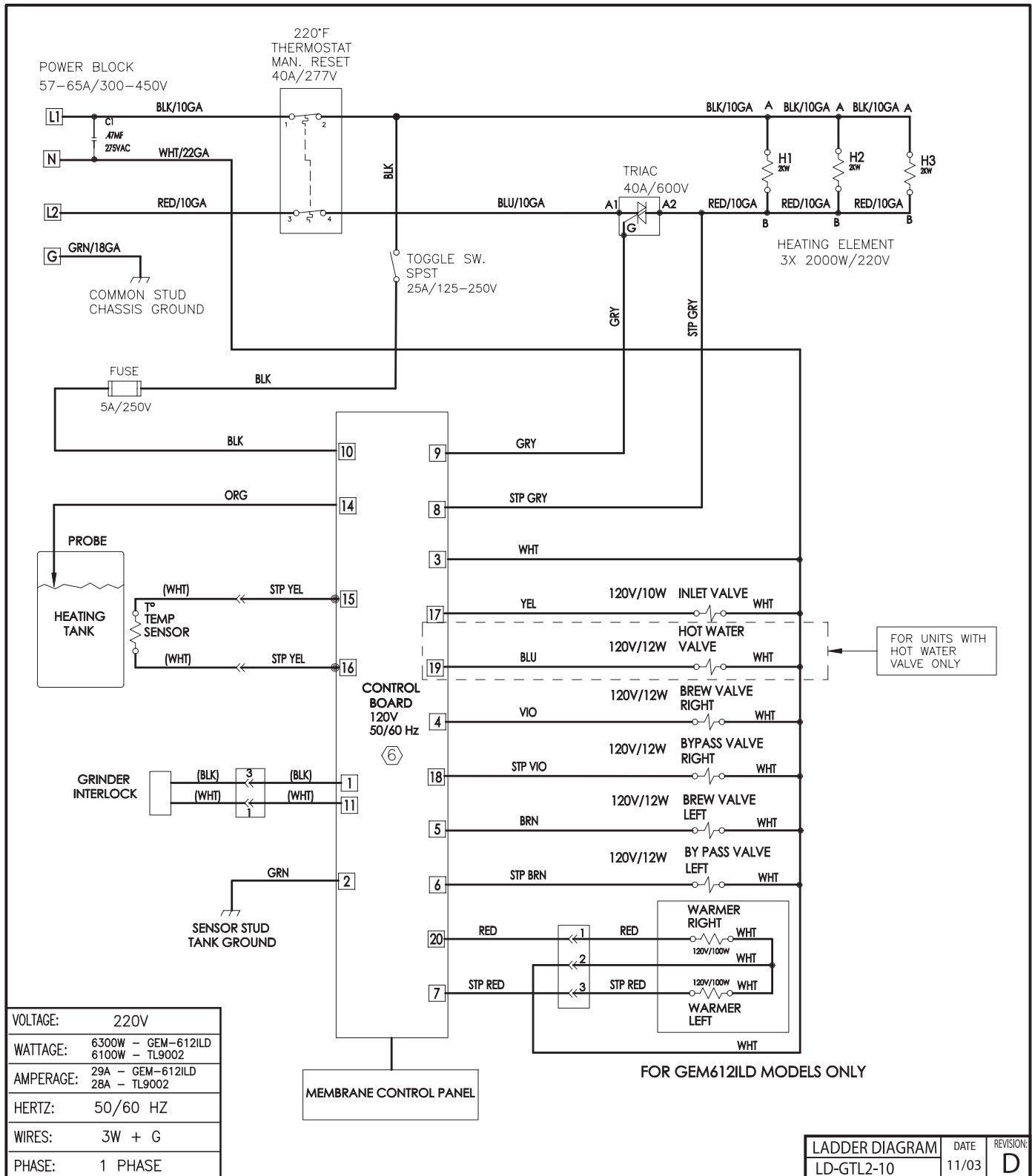

Electrical Schematic

Gem-600ILD & TL-9001

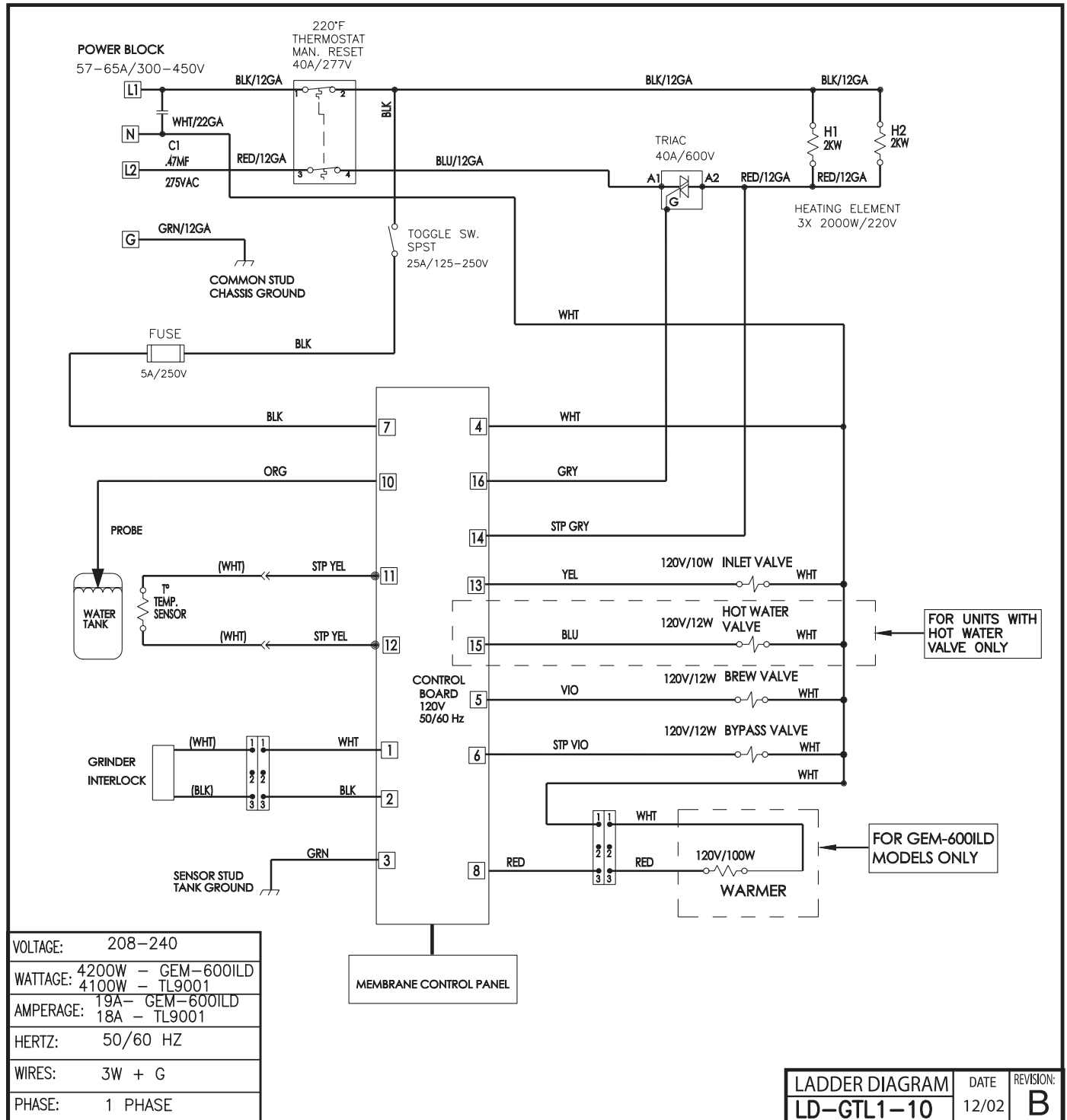



IMPORTANT: Error Codes are indicated by the red Ready to Brew light. If an Error Code occurs the unit will shut down all functions including heating, water inlet, water delivery. ALWAYS confirm Error Code THREE times.

ERROR CODES

Curtis ADS Digital Systems contain various safety features in the electronic circuitry that will shut down the functions of the unit in the event of system failures. Error codes are signalled by the red READY-TO-BREW light blinking.

INTERPRETING THE CODES

ADS ERROR CODES

ADS technology features a state-of-the-art Error Code System. This is designed to quickly advise you of any problems the system may experience expediting service or repair. Occasionally an error reported may be a problem with the water supply or electrical power, NOT directly associated with a fault of the Curtis System itself. An example of this includes:

Clogged Water Filter – Indicated by a Water Level Error Code

Error Codes are indicated by  blinking a pattern as follows:

 = Long Flash

 = Short Flash

 - WATER LEVEL PROBLEM

 - TEMPERATURE SENSOR PROBLEM



Error Codes can only be reset by turning the rear toggle switch to Standby for a minimum of 10 seconds, then returning the switch to ON. Any service required for your Curtis system must be performed by a qualified service technician.



CAUTION: Do not use cleansers, bleach, powders or any other substance that contains chlorine. These products promote corrosion and will pit the stainless steel. USE OF THESE PRODUCTS WILL VOID THE WARRANTY.

CLEANING

REGULAR AND PREVENTIVE MAINTENANCE IS ESSENTIAL IN KEEPING YOUR ADS SYSTEM LOOKING AND WORKING LIKE NEW.

- PREVENTIVE MAINTENANCE

1. Remove spray head from the brewer and clean it weekly or more often in heavy lime areas.
2. Remove and Clean the Satellite faucet seat cups weekly. Replace if cracked or leaking.
3. Remove hot water spout aerator; clean it once a week.
4. Periodic De-Liming of Heat Tank may be necessary especially in areas with especially hard water. (Excessive Lime buildup in heat tank may void warranty.)

- CLEANING

A daily routine of cleaning should maintain its new appearance and insure the good flavor of the coffee.

1. Wipe off any spills, dust or debris from the exterior surfaces.
2. Clean the outside of the brewer and satellite with stainless steel polish. Coarser agents may scratch the machine.
3. Clean and polish inside the Satellite with a SOFT scouring pad.
4. Slide out brew cone. Rinse thoroughly with clean water.
5. Remove the spray head and clean. Clean around the dome area, wiping with a nontoxic cleaner.
6. Clean the brew cone rails with a damp cloth or brush. Dry thoroughly with clean cloth.

PAGE INTENTIONALLY LEFT BLANK

WARRANTY

We hereby certify that the products manufactured by the Wilbur Curtis Company, Inc., are, to the best of our knowledge, free from all defects and faulty workmanship.

The following warranties and conditions are applicable:

- **90 Days for Labor and 1 Year Parts from Date of Purchase from Factory:** This warranty covers all electrical parts, fittings and tubing.
- **40 Months or 40,000 Pounds of Coffee on a set of Grinding Burrs. (ADS Grinders)**
- **2 Years from Date of Purchase:** This warranty covers electronic control boards and leaking or pitting of a stainless steel body of a Brewer or Urn.
- **90 Days from Date of Purchase:** On replacement parts that have been installed on out of warranty equipment

All in-warranty service calls must have prior authorization from the manufacturer. For an RMA (Return Merchandise Authorization) number, call the Technical Service Department at 1-800-995-0417. The Wilbur Curtis Company will allow up to 100 miles, round trip, per in-warranty service call.

CONDITIONS & EXCEPTIONS

The warranty covers original equipment at time of purchase only. The Wilbur Curtis Company, Inc., assumes no responsibility for substitute replacement parts installed on Curtis equipment that have not been purchased from the Wilbur Curtis Company, Inc. The Wilbur Curtis Company will not accept any responsibility if the following conditions are not met. The warranty does not cover and is void under these circumstances:

- 1) **Improper operation of equipment. The equipment must be used for its designed and intended purpose and function.**
- 2) **Improper installation of equipment. This equipment must be installed by a professional, certified technician and must comply with all local electrical, mechanical and plumbing codes.**
- 3) **Wilbur Curtis Company will not be responsible for the operation of equipment at other than the stated voltages on the serial plate.**
- 4) **Abuse or neglect (including failure to periodically clean or remove lime accumulations). Manufacturer is not responsible for variation in equipment operation due to excessive lime or local water conditions.**
- 5) **Replacement of items subject to normal use and wear. This shall include, but is not limited to, light bulbs, shear disks, "O" rings, gaskets, canister assemblies, whipper chambers and plates, mixing bowls, agitation assemblies and whipper propellers.**
- 6) **Any faults resulting from inadequate water supply. This includes, but is not limited to, excessive or low water pressure, and inadequate or fluctuating water flow rate.**
- 7) **All repairs and/or replacements are subject to our decision that the workmanship or parts were faulty and the defects showed up under normal use.**
- 8) **All labor shall be performed during regular working hours. Overtime charges are the responsibility of the owner.**
- 9) **Charges incurred by delays, waiting time, or operating restrictions that hinder the service technician's ability to perform service is the responsibility of the owner of the equipment. This includes institutional and correctional facilities.**
- 10) **All claims under this warranty must be submitted to the Wilbur Curtis Company Technical Service Department before return of the unit to the factory.**
- 11) **All equipment returned to us must be repackaged properly in the original carton. No units will be accepted if they are damaged in transit due to improper packaging.**
- 12) **Damaged in transit.**
- 13) **The resetting of safety thermostats and circuit breakers, programming and temperature adjustments are the responsibility of the equipment owner.**

NO UNITS OR PARTS WILL BE ACCEPTED WITHOUT A RETURN MERCHANDISE AUTHORIZATION (RMA). RMA NUMBER MUST BE MARKED ON THE CARTON OR SHIPPING LABEL.

All in-warranty service calls must be performed by an authorized service center, where service is available. Call the factory for location near you.



WILBUR CURTIS CO., INC.

6913 Acco St., Montebello, CA 90640-5403 USA

Phone: 800/421-6150 ♦ Fax: 323-837-2410

♦ Technical Service Phone: 800/995-0417 (M-F 5:30A - 4:00P PST) ♦ E-Mail: techservice@wilburcurtis.com

♦ Web Site: www.wilburcurtis.com