



**ALP3GT63A800**  
Alpha™ FreshTrac™ 3 Station Brewer  
with three 64 oz. FreshTrac™ Decanters

ITEM NO

PROJECT

DATE

**BREWER FEATURES**

- **G3 Digital Control Module** — Provides precise control over all aspects of brewing in an intuitive, easy-to-operate system. Easily adjust time, volume, temperature, brew functions and more from the front of the brewer
- **Curtis' Exclusive G3 3-Year Warranty** — Provides 3 full years of protection on the digital components
- **Built-In Fine-Tuning Brewing Modes** — Pulse brew for enhanced gourmet flavor extraction
- **On-Board Self-Diagnostics** — Automatically notifies operator of preventive maintenance needs or service requirements
- **Energy Save Mode** — Reduces energy consumption when brewer is idle
- **Factory Set** — For out-of-the-box operation
- **Tamper Resistant** — Changeable access code prevents unauthorized adjustment

**FRESHTRAC™ FEATURES**

- **Silent, Visual Alarm** — A red indicator light provides a simple, intuitive way to monitor coffee freshness
- **Dishwasher Safe** — FreshTrac™ decanters, including tracking receivers can be fully submerged without damage
- **Fully Automatic** — FreshTrac™ starts with every brew cycle

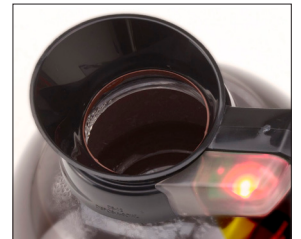

# The Curtis ALPHA™ Brewing System With FreshTrac™ Technology — Beyond Evolutionary, It's Revolutionary

The Curtis ALP3GT™ Brewing Systems with FreshTrac™ technology, a revolutionary way to keep decanters ready to serve freshly brewed coffee. FreshTrac™ includes a flashing, visual indicator to monitor the freshness of coffee right from the point of brewing. This technology eliminates the need to manually manage coffee freshness using hanging timer rings or marking devices.

## ALP3GT63A800

ALPHA™ Automatic Brewer  
with FreshTrac™ Technology

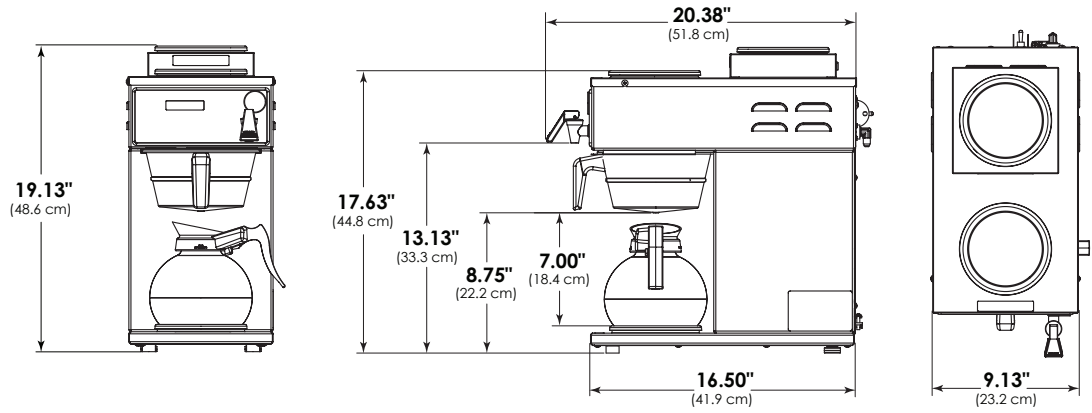

## Electrical Supply Requirements

MODEL #	PHASE	VOLTS	AMPS	HEATING CONFIG	WIRE	WATTS	HERTZ	GAL/HR
ALP3GT63A800	1 PH	120/220V	15.0/15.0A	2X1450W	2/3W+G	1800/3300W	50/60 Hz	4.5/9.0

## Dimensions

MODEL #	HEIGHT	WIDTH	DEPTH	SHIP WEIGHT	SHIP CUBE
ALP3GT63A800	19.13"	9.13"	20.38"	29.1 lbs.	3.64 cu. ft.

## Water Supply Requirements

WATER CONNECT	WATER PRESSURE	MIN. FLOW RATE	WATER TANK VOL.
1/4" Flare	20 - 90 psi	1.0 GPM	1.6 Gal.

SPECIFICATIONS SUBJECT TO CHANGE WITHOUT NOTICE



**WARNING** - These products can expose you to chemicals including Acrylamide and Bisphenol A (BPA), which are known to the State of California to cause cancer and birth defects or other reproductive harm. For more information visit [www.P65Warnings.ca.gov](http://www.P65Warnings.ca.gov)



WILBUR CURTIS CO., INC.  
6913 Acco Street, Montebello, CA 90640-5403  
Telephone: 800-421-6150 · 323-837-2300  
Fax: 323-837-2406  
[www.wilburcurtis.com](http://www.wilburcurtis.com)



AUG/2018 – F-3866 revB