

Chill-X Frozen Beverage Machine



CFBX2
Twin Frozen Beverage Machine
With Two 3.0 Gallon Bowls

Features

Product Options - In addition to traditional frozen beverages, the Chill-X can serve dairy-based and alcohol-based products.

Digital Control Board - Features an innovative digital display that indicates temperature of the beverage and machine settings at the touch of a button.

Preventive Maintenance Reminder - The control board can signal the need for periodic maintenance on key components. Reduces downtime and ensures top performance.

Zero Side Clearance Space - The Patented Ventilation Design allows for air to flow from front to rear, eliminating the need for any side clearance. Maximizes precious counter space.

Front Hinged Lid - No need to remove the lid, simply lift to add product.

Patented Quick Defrost Mode - 75% faster than thawing at room temperature to avoid long defrosting times.

* Optional Auto-Fill Kit (WC-100254K) available.

Chill-X Frozen Beverage Machine

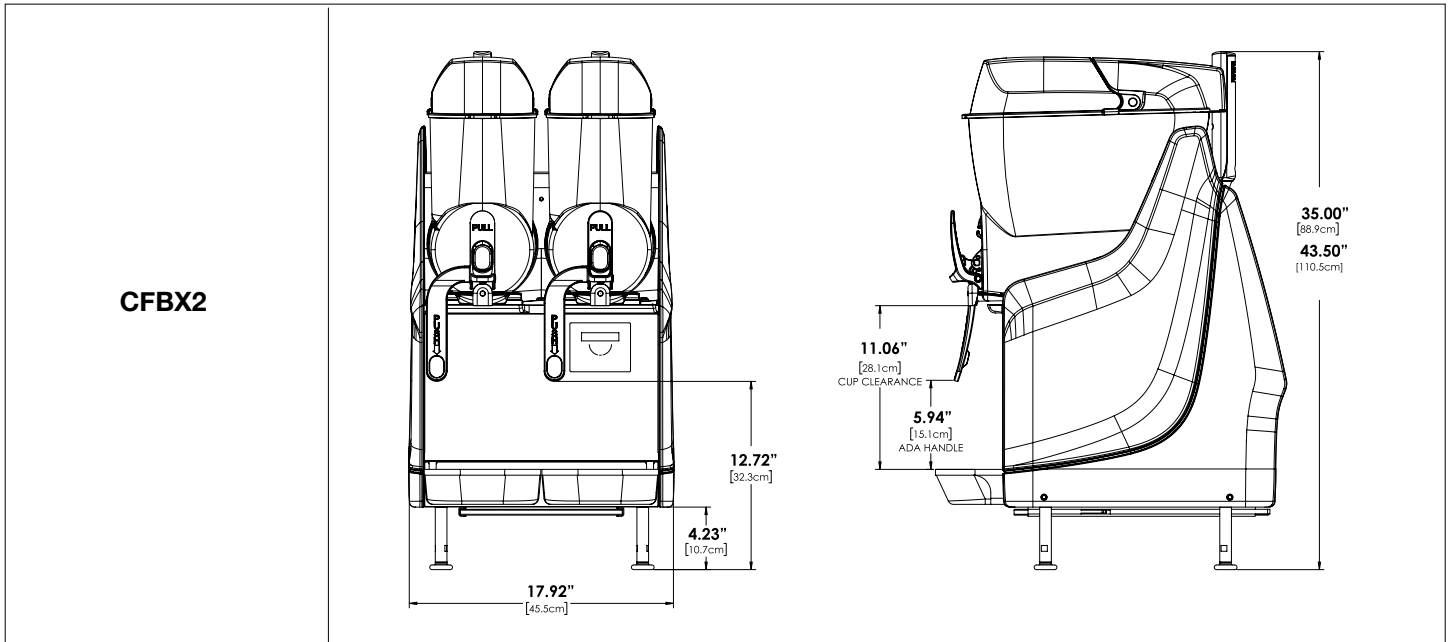

Dimensions

MODEL#	DESCRIPTION	HEIGHT x WIDTH x DEPTH	SHIP WEIGHT	SHIP CUBE
CFBX2	Chill-X Twin Frozen Beverage Machine	35.00" x 17.92" x 23.73"	132.0 lbs.	10.69 cu. ft.

Utility Requirements

ELECTRICAL

MODEL#	PHASE	VOLTS	AMPS	WIRE	WATTS	HERTZ
CFBX2	1 PH	115V	12.0A	2W + G	1380W	60Hz



WARNING - These products can expose you to chemicals including Acrylamide and Bisphenol A (BPA), which are known to the State of California to cause cancer and birth defects or other reproductive harm. For more information visit www.P65Warnings.ca.gov

