

Frozen Beverage Machine



CFB2

Twin Frozen Beverage Machine with Two 3.0 Gallon Bowls



CFB3

Triple Frozen Beverage Machine with Three 3.0 Gallon Bowls

Features

- Patented Ergonomically Designed Push-Pull Handles
- Corrosion-Resistant Stainless Steel Panels
- Large, 3.0 Gallon Bowl Capacity
- Lighted Cover with Safety Lock System
- Standby Mode
- Built-In Timer
- Drip Tray Full Indicator
- Easy to Clean



Perfecting the art of brewing since 1941

Frozen Beverage Machine

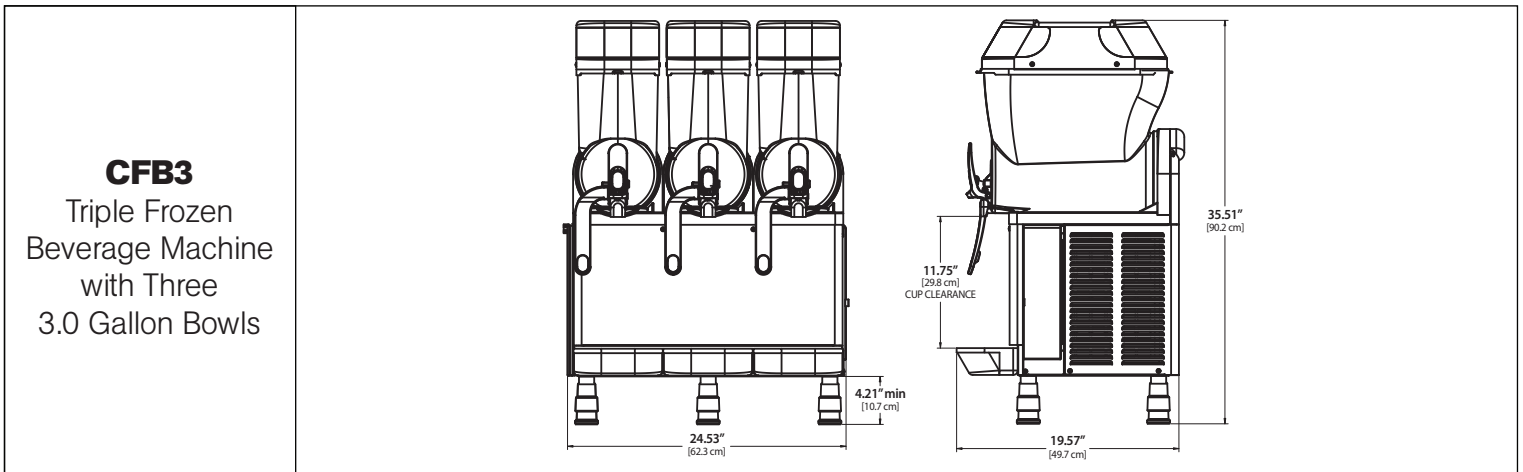
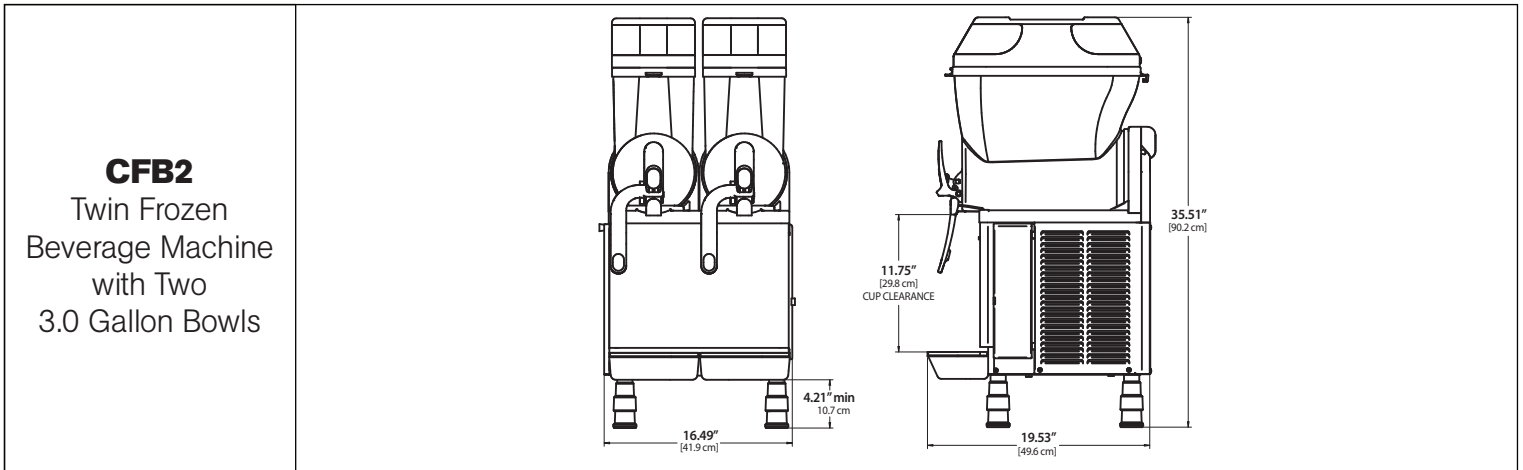

Specifications

MODEL #	DESCRIPTION	CAPACITY	FAUCET CLEARANCE	HEIGHT x WIDTH x DEPTH	SHIP WEIGHT	SHIP CUBE
CFB2	Twin Frozen Beverage Machine	6.0 Gallons (2 x 3.0 Gal.)	11.75"	35.51" x 16.49" x 19.53"	132.0 lbs.	10.69 cu. ft.
CFB3	Triple Frozen Beverage Machine	9.0 Gallons (3 x 3.0 Gal.)	11.75"	35.51" x 24.53" x 19.57"	165.0 lbs.	14.20 cu. ft.

SPECIFICATIONS SUBJECT TO CHANGE WITHOUT NOTICE

Utility Requirements

MODEL #	PHASE	VOLTS	AMPS	ELECTRICAL			
				MIN. CIRCUIT	WIRE	WATTS	HERTZ
CFB2	1 PH	115V	12.4A	15A	2W+G	1500W	50/60 Hz
CFB3	1 PH	115V	14.8A	20A	2W+G	1800W	50/60 Hz

SPECIFICATIONS SUBJECT TO CHANGE WITHOUT NOTICE



WARNING - These products can expose you to chemicals including Acrylamide and Bisphenol A (BPA), which are known to the State of California to cause cancer and birth defects or other reproductive harm. For more information visit www.P65Warnings.ca.gov



Wilbur Curtis Co., Inc. / 6913 Acco Street / Montebello CA 90640
800.421.6150 / 323.837.2300 / www.wilburcurtis.com
Perfecting the art of brewing since 1941