



Curtis GemX Narrow

The fully automated Curtis GemX Narrow saves you precious counter space without sacrificing how much coffee you can offer your customers. The space-saving design is the same width as our GemX Single brewer, but the new compact dispenser design allows for increased coffee options without taking up more space. Doubling your coffee offering while saving space is a win for both you and your customers.

Curtis

the art of brewing

Big volume, small footprint, trusted brand.

The GemX Narrow design is perfect for businesses that see a lot of foot traffic and need coffee readily available to meet surging demands with limited counter space. Operators will benefit from our brewer's ability to dispense quickly and brew continuously. The 10.5" width design allows operators to double their coffee offerings without taking up additional counter space.



Features

Save Valuable Counter Space – Double your coffee offerings without taking up additional counter space. One warmer stand holds two 1.5 Gal dispensers.

Quick and Easy Updates – Software and recipe updates take less than 30 seconds through the USB port.

Reduce Waste – Supports smaller batch sizes for non-peak hours.

Preloaded Recipes – Simplify the installation process by choosing from our preloaded recipes. No calibration required.

User Friendly – Simple and easy to use for both operators and customers.

Freshness Digital Indicator – Digital quality control indicators help maintain the quality of the coffee by removing any guesswork.

Parts Commonality – Uniformity of components allows our existing service partners to cross over and support new models with a minimal learning curve.

Best in Class Warranty – GemX Narrow is backed by a three-year parts and labor warranty on the digital control board and touch screen. All other components are supported with a two-year parts and labor warranty. See warranty statement for full details.

Dimensions

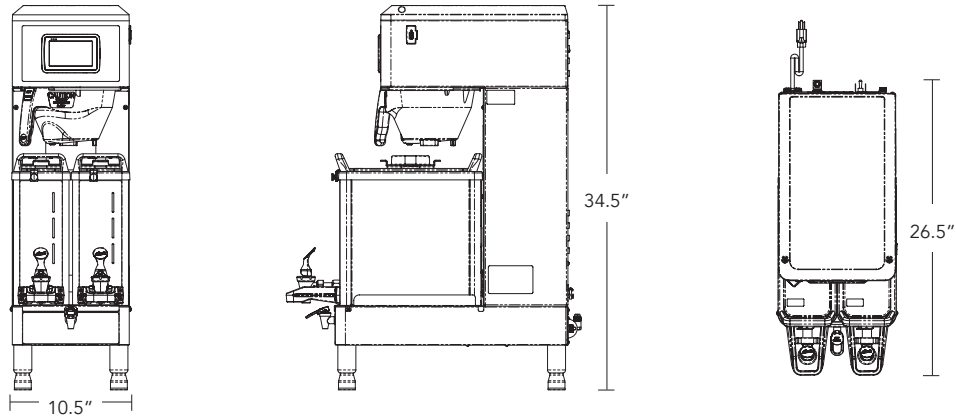

Technical Overview

Model #	G4GEMXN63A1000
Storage Capacity	1.5 Gal x2
Batch Size (S)	0.5 Gal, 1.0 Gal & 1.5 Gal
USB Ports	√
Water Tank Capacity (Gal)	2.2
Water Connection	3/8 " Flare
Heater Configuration	2X 1600W
Certifications	UL, NSF

Power Configuration

120 Volts

220 Volts

Brewing Capacity (Gal/Hr)	4.5	10
Cups Per Hour (16oz)	36	80
Electrical Requirements	120V, 13.5Amps, Single Phase	220V, 13.5Amps, Single Phase
Wattage	1650	2800
Wire	2W + G	3W + G

Accessories



GEM3XN
1.5 Gal. Dispenser with
IntelliFresh & FreshTrac
(Two Included)



GEM5XN
IntelliFresh® Warmer
Stand
(Sold Separately)



WC-61418K
Lever, Touchless Dispense
(Sold Separately)



WARNING - These products can expose you to chemicals including Acrylamide and Bisphenol A (BPA), which are known to the State of California to cause cancer and birth defects or other reproductive harm. For more information visit www.P65Warnings.ca.gov



1-800-421-6150

www.wilburcurtis.com