

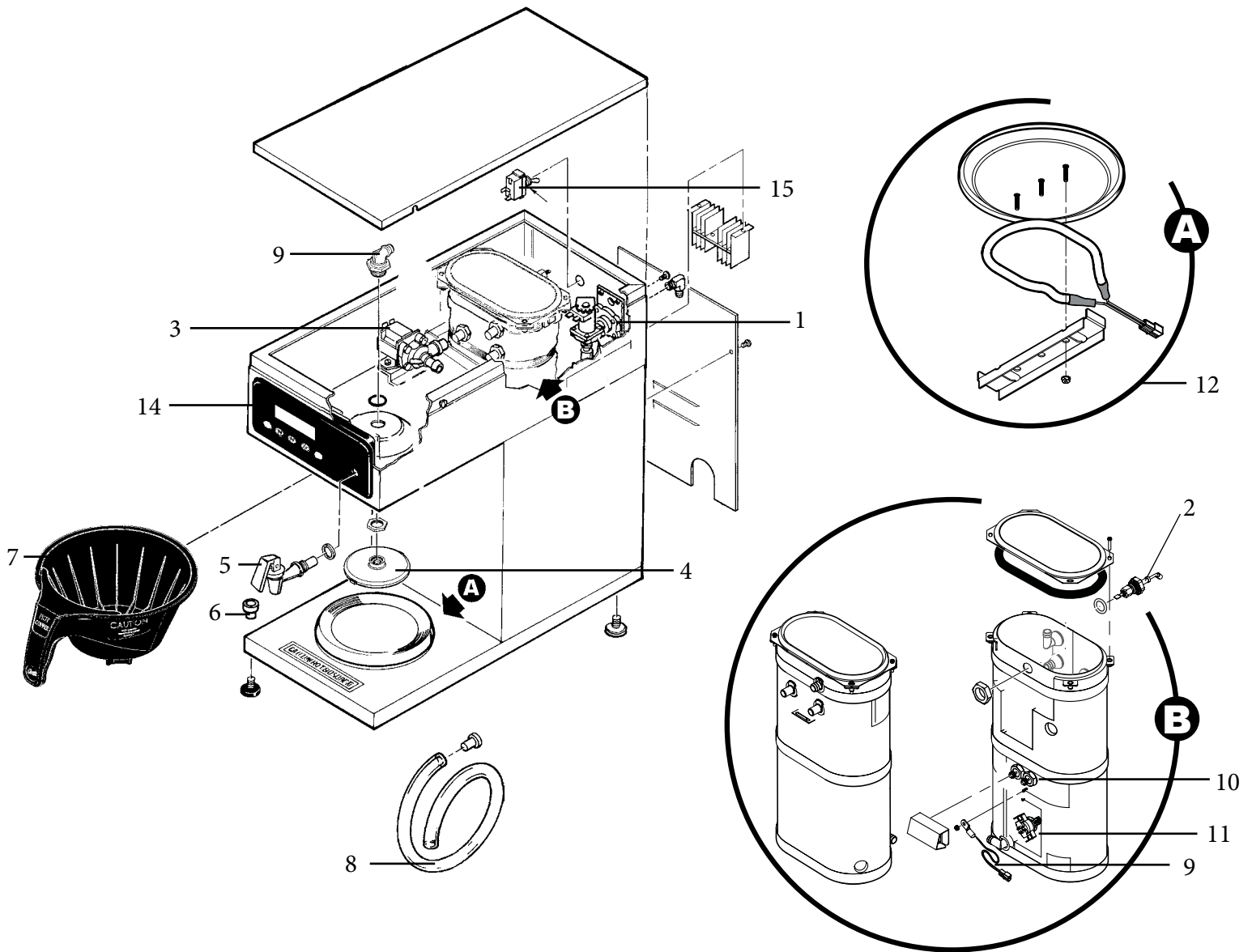

CURTIS DECANTER BREWER TROUBLESHOOTING GUIDE



BREWER PARTS IDENTIFICATION



WATER RELATED

PART #	DESCRIPTION
1. WC- 826L	VALVE, INLET 1.0 GPM 120V
2. WC-5527K	KIT, PROBE WATER LVL FITTING, ORING, NUT
3. WC- 889	VALVE, DUMP LEFT 120V 12W
4. WC-29025	SPRAYHEAD, PURPLE ADVANCE FLOW
5. WC-37252	KIT, HOT WATER FAUCET REPLACEMENT
6. WC-1806	SEAT CUP, SILICONE
7. WC-3621-101	BREW CONE, COFFEE
8. WC-5310	TUBING, SILICONE

HEAT RELATED

PART #	DESCRIPTION
9. WC-1438-101	SENSOR, TEMPERATURE TANK
10. WC- 917-04	HEATING ELEMENT
11. WC- 523	THERMOSTAT, HI LIMIT HEATER
12. WC- 972-102	BREW WARMER
13. WC-6193-0	TRIAC, 40A 600V (NOT ILLUSTRATED)

MASTER CONTROL

14A. WC-37061	KIT, LABEL & UCM ALPHA 1GT
14B. WC-37062	KIT, LABEL & UCM ALPHA 2GT
14C. WC-37063	KIT, LABEL & UCM ALPHA 3GT
15. WC- 102	SWITCH, TOGGLE DPST 25A 125/250VAC

PARTS IMAGES

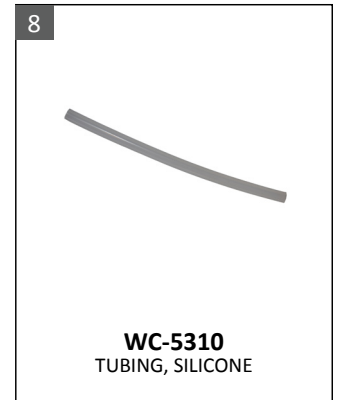
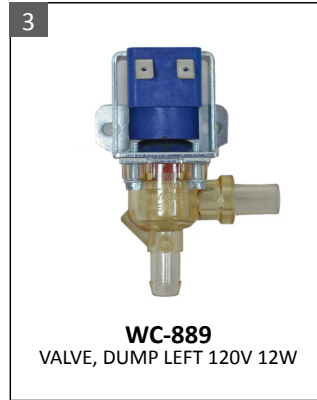

TROUBLESHOOTING INSTRUCTIONS

POWER ISSUES

The unit will not turn on:

- 1 Check if the panel breaker is turned on. If it is, proceed to STEP 2.
- 2 Check the voltage at the receptacle it should read: L1-N = 120v, N-G = 0v. Proceed to STEP 3 if accurate.
- 3 Check if the power cord is properly connected to the receptacle. If it is, proceed to STEP 4.
- 4 Check the toggle switch if it is in the ON position. If it is ON, proceed to STEP 5.
- 5 Check the voltage at the power block, it should read: L1-N = 120v, N-G = 0v.
- 6 Check the voltage at the reset thermostat, it should read 120v.
- 7 Check the voltage at the toggle switch, it should read 120v.
- 8 Verify 120v between pins #8 and #16 on molex connector at UCM.
- 9 If all steps were taken and the unit still does not turn on, replace the UCM.

HEATING ISSUES

Not heating:

LCD reads "Heating"

Yes: Verify 120 volts between #2 & #4 on both sides of the Manual Reset Thermostat. If no, reset or replace the Manual Reset Thermostat.

Yes: Verify 120 volts across the Toggle Switch. If no, replace the toggle switch.

Yes: Verify 120 volts across the Heating Element. If yes, replace the Heating Element. If no, verify 120 volts between the Triac gate, Neutral, and L1. If yes, replace the Triac, if no, replace the UCM.

No: Verify that the panel breaker is turned on and the receptacle has 120 volts. If not, consult an electrician.

Overheating/Steaming:

LCD reads "Heating"

Verify that the resistance on the Temperature Sensor is less than 10k ohms with a hot tank (200+ degrees) If no, verify correct mounting and that the walls of the tank are free of mineral deposits. If yes, bypass the sensor using a jumper with a 5k ohm resistor. If the LCD reads "ready" and the unit stops heating, replace the temperature sensor, if not, replace the UCM.

LCD reads "Ready to Brew"

Check the triac for continuity across A1 & A2, if continuity is present, replace the triac, if no continuity, replace UCM.

- i** Ensure that the temperature is adjusted to compensate for high elevation. The factory setting is 200 degrees. The temperature setting will need to be reduced Two degrees for every One Thousand feet of elevation.

WARMER ISSUES

No power to any warmer:

Verify correct programming: (Model number).

Not heating:

Verify 120v at heating element.

Yes: Replace heating element.

No: Verify that the connections and wirings are good. If OK, replace UCM.

Constantly hot, even when turned off:

Ensure proper resistance value on the heating element between 140-170 ohm.

Ensure wiring is not shorted to ground.

Replace UCM.

TANK FILLING ISSUES

Not filling:

- Yes: Does the LCD read “Water Level Error”?
- Yes: Verify the flow rate to be a minimum of 1 gpm from outlet of the water filter. If not, ensure that the inlet side of the water filter is receiving a minimum of 1 gpm. If yes, replace the water filter. If not, consult a plumber.
- No: Remove the orange wire from the probe. Does the tank start filling?
- Yes: Replace water level probe
- No: Replace the UCM

Overfilling:

- Turn OFF toggle switch.**
- Does the tank continue to fill?
- Yes: Replace water inlet valve
- No: Ground the probe wire to chassis.
- Does the tank continue to still fill?
- Yes: Replace the UCM
- No: Replace Water Level Probe

BREWING ISSUES

LCD does not read “Brewing”:

If the LCD reads “Ready to Brew” and no response when Brew Button is pressed, replace the UCM.

LCD reads “Brewing”:

No water flow from the sprayhead:

Does water flow from the hot water faucet? If yes, verify 120 volts at the dump valve coil. If voltage is present at the dump valve coil, replace the dump valve. If 120 volts is not present at the dump valve coil, confirm continuity of wiring between molex connector and Dump Valve. If okay, replace the UCM. (Verify the resistance on the dump valve coil to be open in one direction, and under 2k ohm in the other direction BEFORE REPLACING THE UCM) If water does not flow from the hot water faucet, replace the Water Level Probe.

Brewing Short Pots:

Verify that the Hot Water Tank is filling correctly. (See Tank Filling issues)

i Before replacing any parts, verify the following:

Verify that the Dump Valve outlet fitting on the tank, the tubing between the tank outlet and the Sprayhead fitting, the Sprayhead, and Dump Valve are clear of obstructions.

Ensure correct alignment of the sprayhead fitting and that the tubing is routed properly to allow for maximum water flow. (No Kinks)

Overflowing the Pot:

- Ensure that the Sprayhead has not been removed. Replace as needed.
- Ensure that the Hot Water Tank is not overflowing (See Tank Filling Issues)
- Ensure that hot water is not flowing from the Dump Valve when the toggle switch is turned off. If it is, replace the dump valve.
- Ensure Cold Brew Lock is set to 5 degrees



Wilbur Curtis Co., Inc.

6913 Acco Street, Montebello CA 90640
Customer Service: 800.421.6150 | 323.837.2300
csrassistance@wilburcurtis.com
Tech Support: 800.995.0417
www.wilburcurtis.com